

SXP in a nutshell

Manuel Izquierdo

Contact: manuel.izquierdo@xfel.eu

24 January 2022



SXP in a nutshell

X-rays

- SASE 3 source (0.25 – 3 KeV)
- Monochromatization
 - 50 l/mm RP 3000
 - 150 l/mm RP 10000
- Variable polarization
 - Apple X undulators

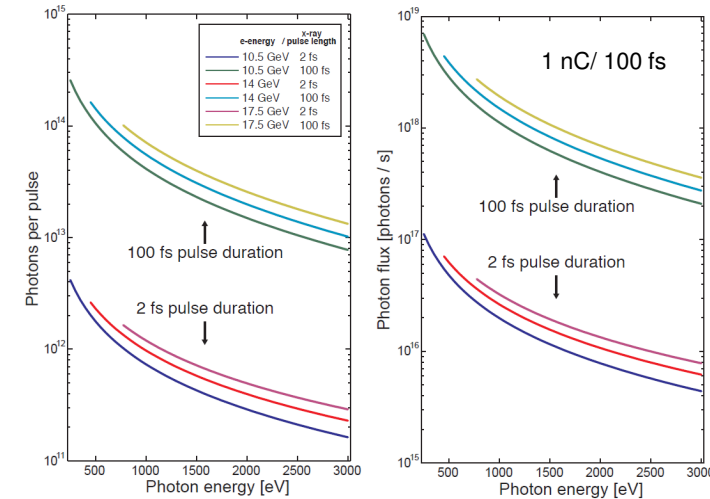
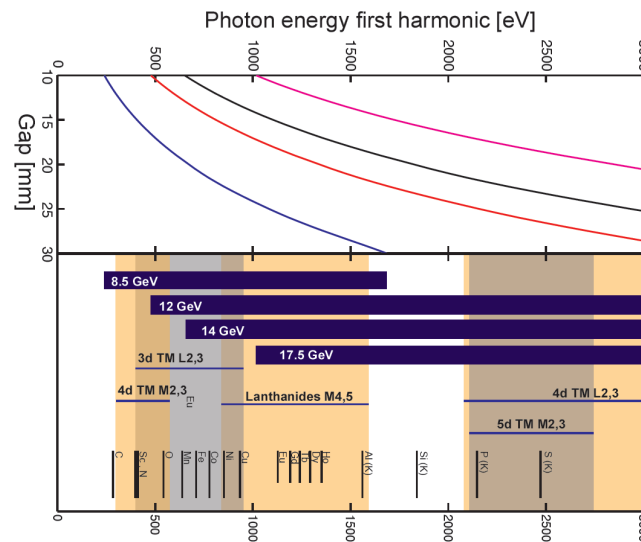

Adapted from the SCS Conceptual design report

Laser

- Extended pump wavelength (200 nm – THz)
- European XFEL

The SXP scientific community

TR-XPES

Denmark		6 Groups
France		9 Groups
Germany		13 Groups
Italy		5 Groups
Poland		9 Groups
Russia		25 Groups
Spain		15 Groups
Sweden		7 Groups
Switzerland		4 Groups
UK		3 Groups
USA		1 Group



Sweden		4 Groups
Germany		1 Group
USA		2 Groups
Germany		7 Groups
USA		4 Groups
Spain		1 Group
France		1 Group
Netherlands		1 Group
Israel		1 Group

CBA

HCI

The SXP instrument

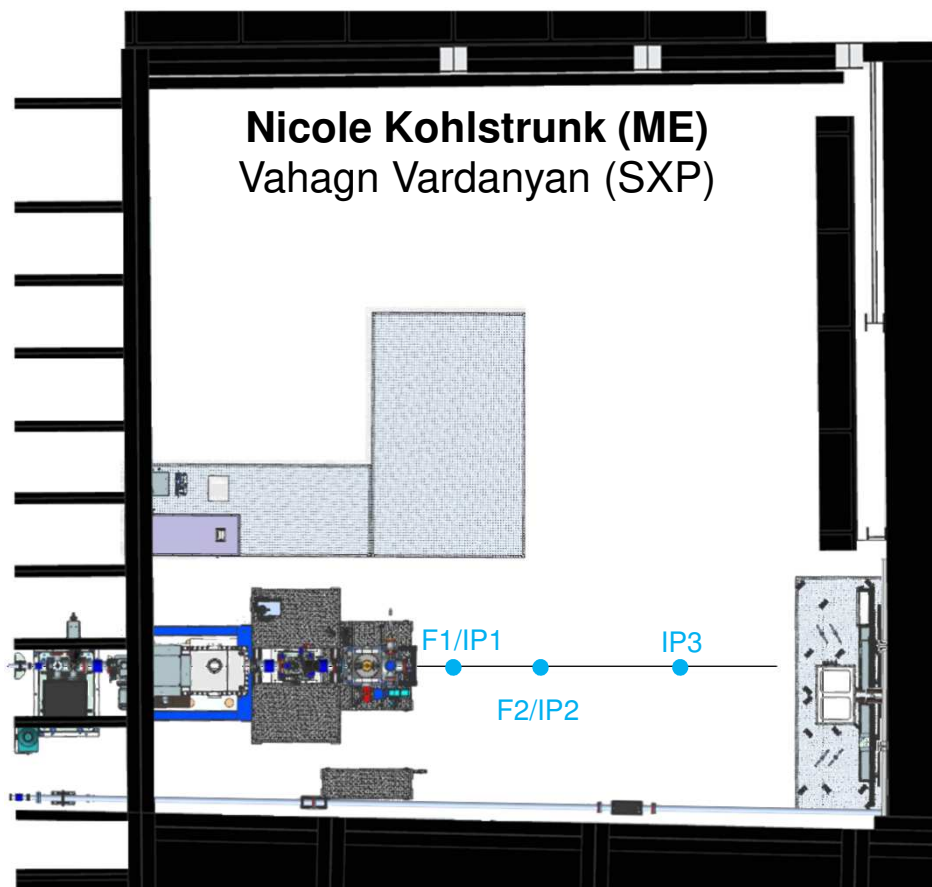

- Compact beamline design
 - All permanent beamline components upstream
- KB focusing system with bendable mirrors
 - First implementation → fixed foci mirrors

Distance VF (m)	HF @ 0.3 KeV	VF @ 0.3 KeV
2.2	2.08	1.39
3	2.64	2.78
5.5	4.37	5.09

SXP First implementation

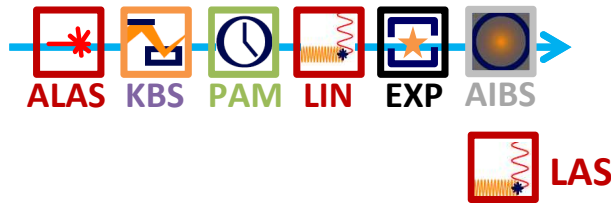

Patrik Grychtol
Laser specialist

KBS

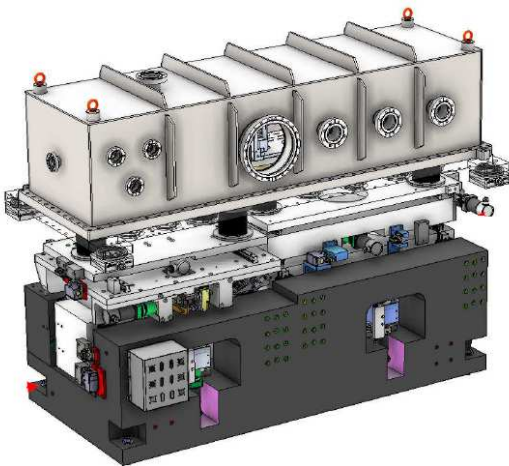

Talk by Maurizio Vannoni
European XFEL

ALAS

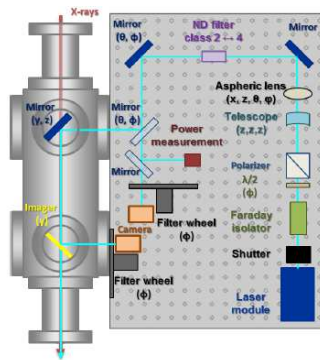

PAM+

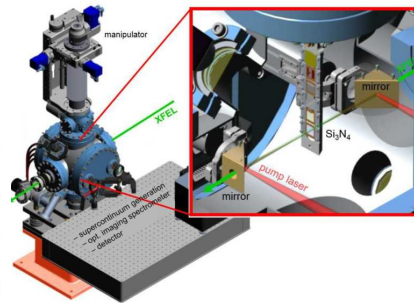

Talk by Patrik

LIN

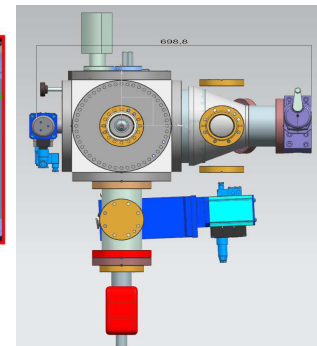

TR-XPES

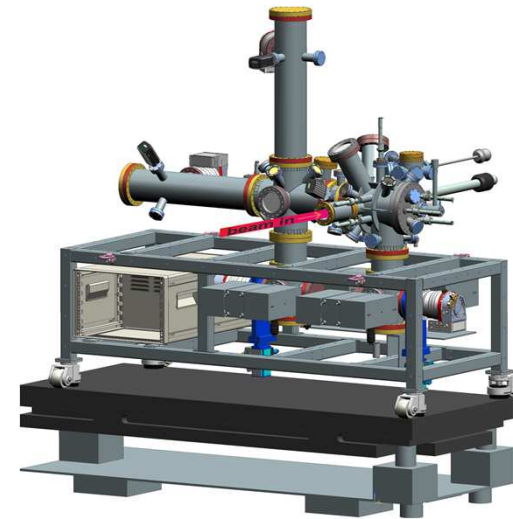

Talk by Gerd Schönhense

Data Analysis: End to end data solutions



David Doblas
R&D SXP PEDAL:
"SXP Plural
Experiment Data
Analysis Libraries"

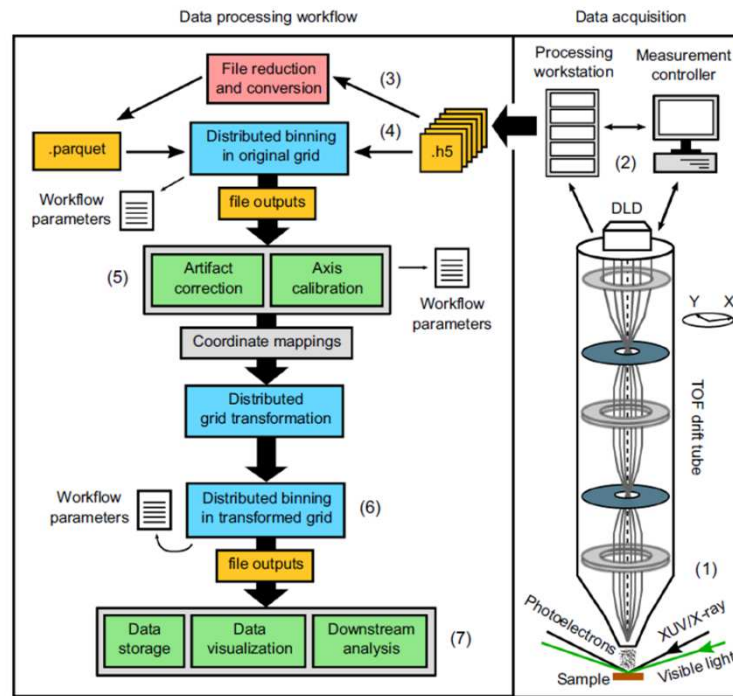

SCIENTIFIC DATA

OPEN **ARTICLE** **An open-source, end-to-end workflow for multidimensional photoemission spectroscopy**

R. Patrick Xian¹, Yves Acremann², Steinn Y. Agustsson³, Maciej Dendzik¹, Kevin Bühlmann², Davide Curcio⁴, Dmytro Kutnyakhov⁵, Federico Pressacco^{5,6}, Michael Heber⁵, Shuo Dong¹, Tommaso Pincelli¹, Jure Demsar³, Wilfried Wurth^{5,6,8}, Philip Hofmann⁴, Martin Wolf¹, Markus Scheidgen^{1,7}, Laurenz Rettig¹ & Ralph Ernstorfer¹

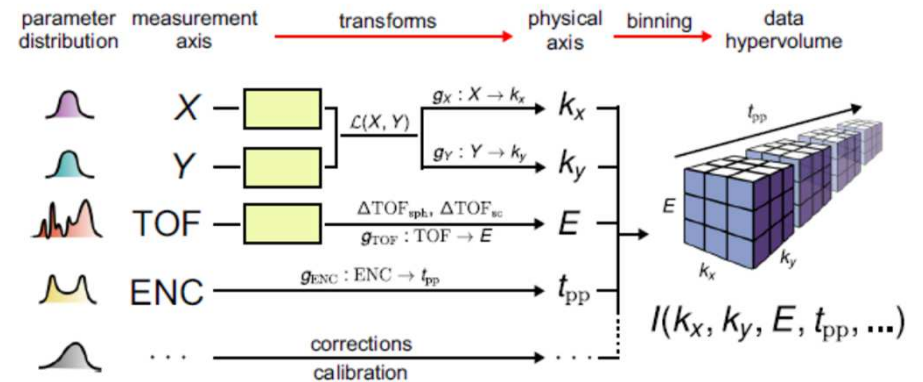

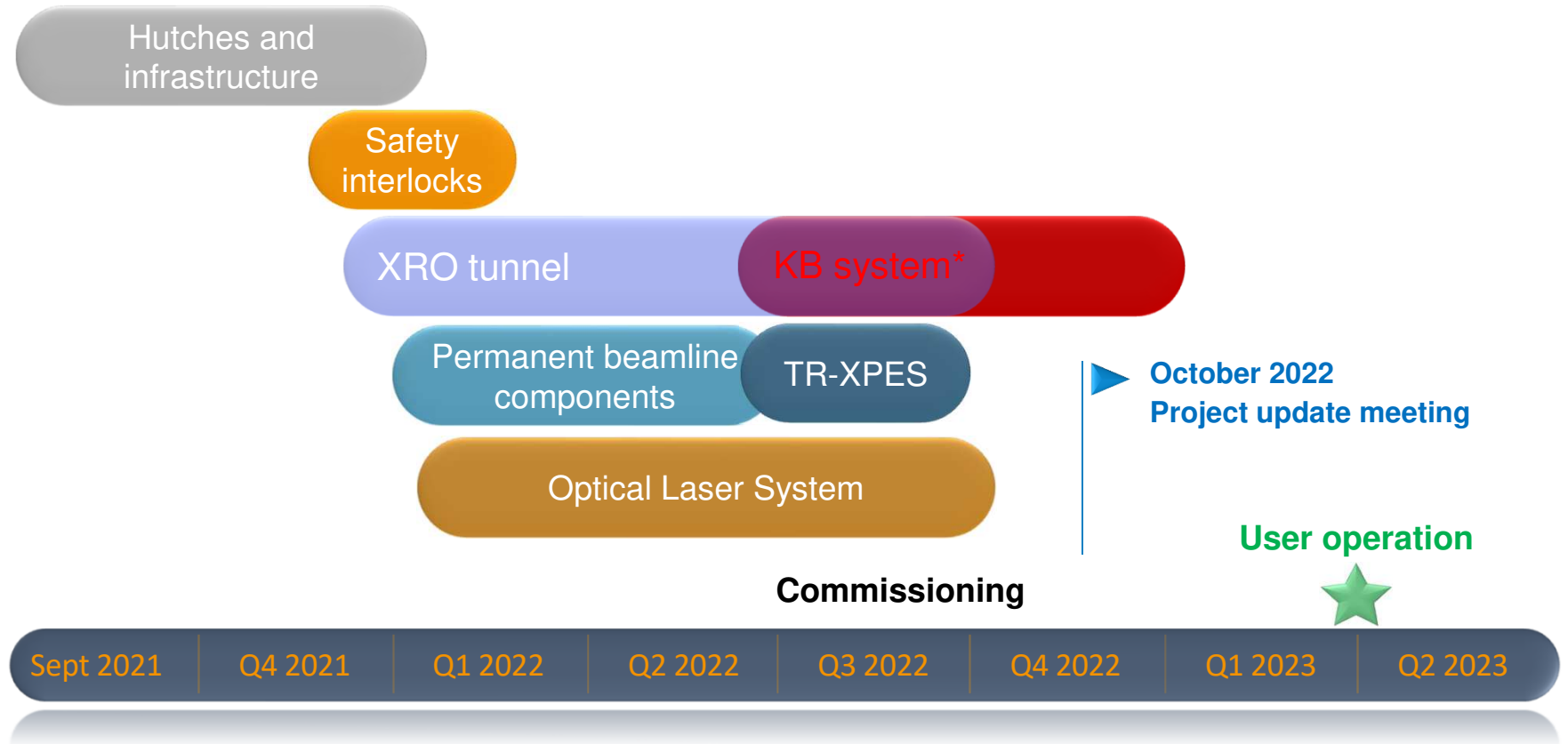

Perspectives (I)

XFEL.EU TR-2022-001B

TECHNICAL DESIGN REPORT

Scientific Instrument Soft X-Ray Port (SXP). Part B: First Implementation

January 23, 2022

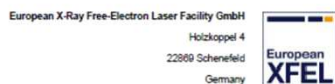

Contents

Figures	7
Tables	8
1 Introduction	9
1.1 SXP experiment areas	10
1.1.1 SXP experiment hutch	10
1.1.2 SXP rack room	13
1.1.3 SXP control room	16
1.1.4 SXP laser enclosure	17
1.2 Timeline of the SXP project	19
2 X-ray optics	21
2.1 SASE3 X-ray beam transport	21
2.1.1 Offset mirrors	24
2.1.2 Distribution mirror	24
2.1.3 Soft X-ray monochromator	26
2.2 SXP focusing capabilities	29
2.2.1 Focus with M2 and the monochromator	30
2.2.2 Refocussing units for TR-XPES	31
2.2.2.1 Vertical refocusing	32
2.2.2.2 Vertical and horizontal refocusing	34
2.2.3 KB focusing	36
2.2.3.1 KB focusing with fixed foci mirrors	40
3 Optical laser delivery	41
3.1 Overview of laser capabilities	41
3.2 Central SASE3 optical laser system	44
3.3 Central laser delivery at SXP	46
3.4 SXP instrument laser enclosure	48
3.4.1 800 nm pulses	49
3.4.2 1030 nm long pulse beam	49
3.4.3 Frequency conversion	50
3.4.3.1 Second, third, and fourth harmonic generation	50
3.4.3.2 Optical parametric amplification	55
3.4.3.3 THz generation	56

January 23, 2022
2 of 101

XFEL.EU TR-2022-001B
TDR: SXP-B

4 Permanent beamline components	59
4.1 Alignment laser system: ALAS	60
4.1.1 Overview	60
4.1.2 Operation	61
4.1.3 Implementation	61
4.1.3.1 Breadboard	62
4.1.3.2 In-vacuum devices	65
4.1.3.3 Support	66
4.1.4 Controls	66
4.2 Kirkpatrick-Baez X-ray focussing system: KBS	66
4.2.1 Overview	66
4.3 Pulse arrival monitor: PAM	66
4.3.1 Overview	66
4.3.2 Operation	67
4.3.3 Implementation	68
4.3.3.1 Laser	68
4.3.3.2 Breadboard	69
4.3.3.3 In-vacuum devices	71
4.3.3.4 Support	73
4.3.4 Controls	73
4.4 Optical laser in-coupling: LIN	73
4.4.1 Overview	73
4.4.2 Implementation	75
4.4.2.1 In-vacuum devices	76
4.4.2.2 Support	76
4.4.3 Controls	76
4.5 Active instrument beam stop: AIBS	76
4.6 Vacuum system	77
4.6.1 Overview	77
4.6.2 Implementation	80
4.6.2.1 Vacuum control	81
4.6.3 Control system	81
5 TR-XPES: the first experimental setup	82
6 Data Analysis	83
6.1 The Karabo framework	83
6.2 The DAQ system	83
6.3 JupyterHub on the Maxwell cluster	84
6.4 Users and their workflows	85

XFEL.EU TR-2022-001B
TDR: SXP-B

January 24, 2022
3 of 100

6.5 Introduction to metrope	86
6.6 Data pipeline	87
6.7 First implementation	89
7 Operation	90
7.1 Standard operation	90
7.2 Parallel operation	92
A SASE3 source parametrization	94
B Beam coordinates	96
C Note on contributions	98
D Acknowledgements	100
Bibliography	100

Perspectives (II)

Multi-technique detection

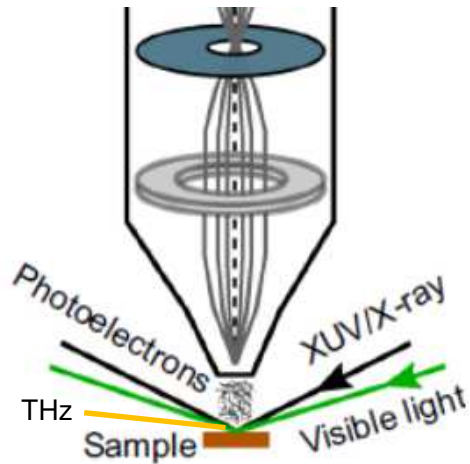

HHG source

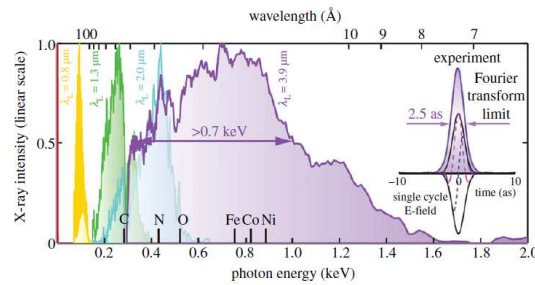

SCS	SQS	SCS	SQS	SXP
SQS	SCS	SXP	SCS	SQS

SXP 20%

EBIT (Electron Beam Ion Trap)

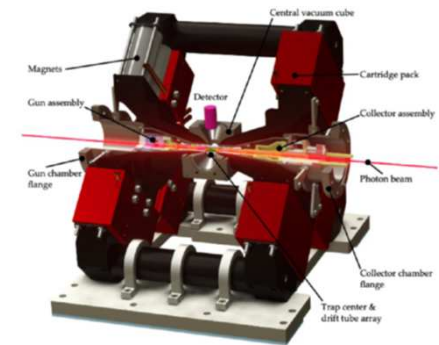

Reflectivity:

- Optical pump - X-ray probe
- X-ray pump - optical probe

THz detection



Vahagn Vardanyan
 R&D SXP AIMS:
 "Advanced Instrument
 Mechanical Systems"

Perspectives (III)

TR-SW-ARPES

Momentum-resolved electronic structure at a buried interface from soft X-ray standing-wave angle-resolved photoemission

A. X. GRAY^{1,2,3}, J. MINÁR⁴, L. PLUCINSKI⁵, M. HULBEN⁶, A. BOSTWICK⁷, E. ROTENBERG⁷, S.-H. YANG⁸, J. BRAUN⁴, A. WINKELMANN⁹, G. CONTI^{1,2}, D. EITENEER^{1,2}, A. RATTANACHATA^{1,2}, A. A. GREER^{1,2}, J. CISTON¹⁰, C. OPHUS¹⁰, G. RIJNDERS⁶, D. H. A. BLANK⁶, D. DOENNIG¹¹, R. PENTCHEVA¹¹, J. B. KORTRIGHT², C. M. SCHNEIDER⁵, H. EBERT⁴ and C. S. FADLEY^{1,2}

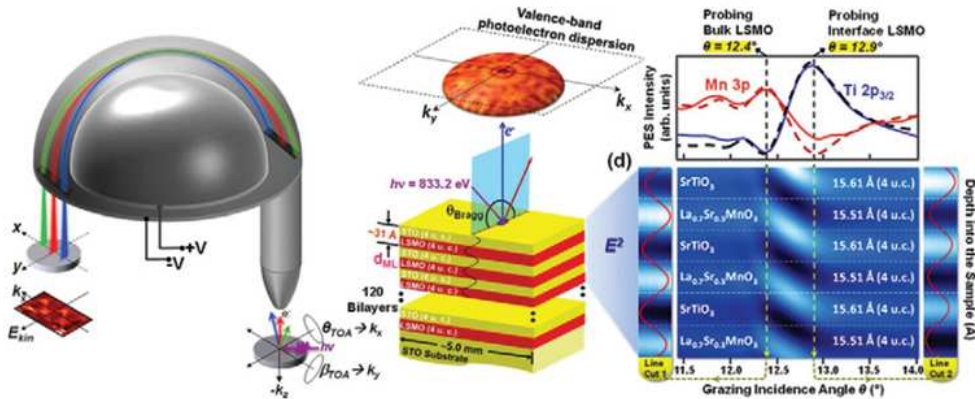

Four Wave mixing (SHG)

PHYSICAL REVIEW LETTERS **120**, 023901 (2018)

Editors' Suggestion Featured in Physics

Soft X-Ray Second Harmonic Generation as an Interfacial Probe

R. K. Lam,^{1,2} S. L. Raj,^{1,2} T. A. Pascal,³ C. D. Pemmaraju,⁴ L. Foglia,⁵ A. Simoncig,⁵ N. Fabris,^{6,7} P. Miotti,^{6,7} C. J. Hull,^{1,2} A. M. Rizzuto,^{1,2} J. W. Smith,^{1,2} R. Mincigrucci,⁵ C. Masciovecchio,⁵ A. Gessini,⁵ E. Allaria,⁵ G. De Nino,^{5,8} B. Diviacco,⁵ E. Roussel,⁵ S. Spampinati,⁵ G. Penco,⁵ S. Di Mitri,⁵ M. Trovò,⁵ M. Danailov,⁵ S. T. Christensen,⁹ D. Sokaras,¹⁰ T.-C. Weng,¹¹ M. Coreno,^{5,12} L. Poletto,⁶ W. S. Drisdell,² D. Prendergast,³ L. Giannessi,^{5,13} E. Principi,⁵ D. Nordlund,¹⁰ R. J. Saykally,^{1,2,6} and C. P. Schwartz^{3,10,†}

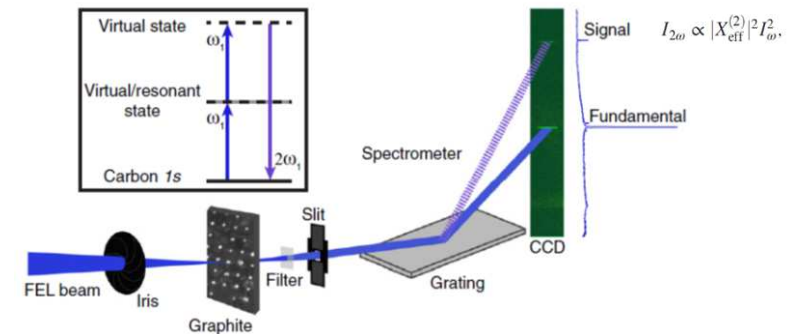

Perspectives (IV)

TR-NAPP solid-gas and solid-liquid interfaces

TR-NAPP liquid-gas interfaces

VC HAXPES (Nilsson, P22)



Rev. Sci. Instrum. 90, 103102 (2019)

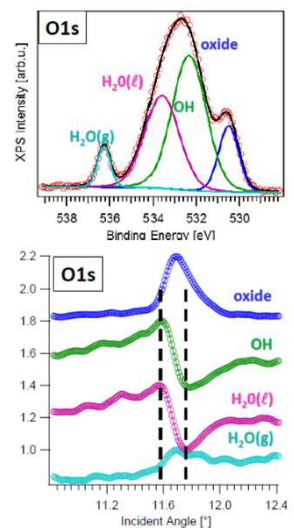
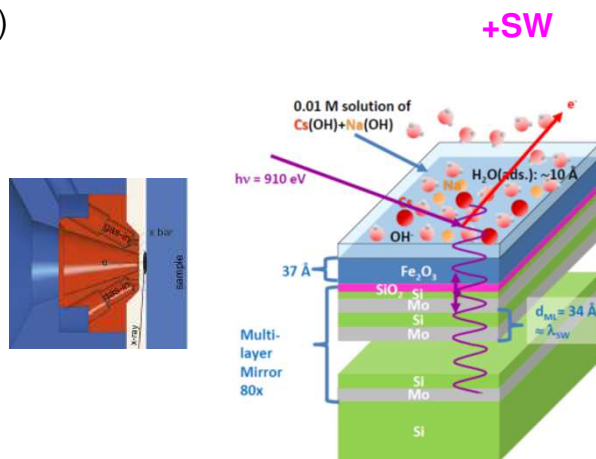

LJ-PES (Bernd Winter, FHI, P04)

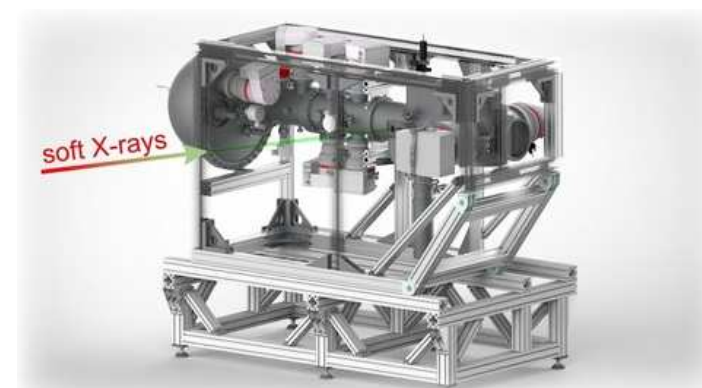

Acknowledgments

TR-XPES consortium

Kai Rossnagel, Sebastian Thiess, Jens Buck, Markus Scholz and Gerd Schönhense

EuXFEL

Instrumentation Department: Nicole Kohlstrunk & Daniele La Civita (ME); Maurizio Vannoni, Natalia Gerasimova, Antje Trapp (XRO); Martin Dommach (VAC); Jia Liu & Jan Grünert (XPD); Max Lederer (LAS); Harald Sinn

Data Department: Nicola Coppola, Nerea Jardon, Michael Fobian, Emmanuelle Melegari, Joern Moebius, Hector Vega, Patrick Gessler (EEE); Steffen Hauf (CRTL); Kimon Filippakopoulos, Janusz Schuba, Krzysztof Wrona (ITDM); Monica Turcato (DETOPS); Chris Youngmann (PTC); Steve Applin

SRP: Zunaira Ansari, Vasilii Bazenhov, Eric Boyd, Michael Prollius, Pouneh Saffari and Tobias Haas

TS: Ulf Brueggmann, Torsten Schon, Tobias Clever, Ralf Emmerich, Tobias Bartsch, Sueleyman Arslan, Christoph Staeps, Lorenz Kersting

ADM: Martin Hagitte, Jan Ruescher, Florian Guhlman

PMO: Gerd Wellenreuther & Adriano Violante

Serguei Molodtsov & the EuXFEL MB

SXP group



Thank you for your attention!