

12th call for proposals

HED HiBEF

...closes **Nov 8, 2023 at 16:00**

(German local time)

Submit via web portal:

<https://in.xfel.eu/upex>

Never been at HED? No problem: look at our hutch using

[the virtual tour \(link\)!](#)

https://www.xfel.eu/facility/instruments/hed/

European XFEL

VISITORS CONTACTS CAREERS UPEX EN

FACILITY ORGANIZATION SCIENCE NEWS AND EVENTS USERS

Overview Operation Accelerator Beamlines Instruments User Laboratories Safety and Environment Comparison Virtual Tour Construction

FXE HED MID SCS SPB/SFX SQS

Videos and Photos Science Programme Instrument design User Consortium and External Funding Documentation Publications Group members Links

> Facility > Instruments > HED

Scientific Instrument HED

Take our virtual tour and look at the hutch!

Proposal preparation for the HED instrument



Call for Proposals - Frequently asked Questions and Answers

What is HED?

The High Energy Density (HED) scientific instrument is a new, unique platform for experiments combining hard X-ray FEL radiation

Possible experiments at HED in this call:

Scientific drivers:

- Isochoric heating (using the focused intense XFEL pulse to create a plasma)
- DiPOLE 100X
(incl. a XRD standard configuration and one spectroscopy community proposal)
- Pump-probe laser (PP)
- 100 TW laser RE.LA.X (incl. a standard configuration)
- *DAC in IC2 → please submit during next call 13, in 6 months*

Contact the instrument staff for detailed information.

We encourage to use our **standard configurations
(see next slide – about 2x higher chance to get scheduled)**

All proposals must be submitted through UPEX (<https://in.xfel.eu/upex>)

Alternating high-energy setups in IC2, standard configuration proposals

- HED users are always welcome to submit regular (non-standard platform) proposals which fit to the instrument capabilities, according to the details given in the pdf -document is linked to our HED-HiBEF website.
 - However, before submitting your proposal, it is **mandatory to discuss your proposal with the instrument staff**, as not all combinations of our capabilities are technically feasible.
- DiPOLE XRD and DAC XRD proposals compete for the same resources, e.g.
 - beamtime at 16.3 GeV electron energy and
 - IC2 target chamber access.

Therefore, European XFEL decided to schedule the DiPOLE platform in each second half of a calendar year. Consequently, in this call for 2024-II, no standard DAC XRD proposals will be accepted, in favor of DiPOLE XRD proposals and minimum setup change-overs.
- We anticipate that in the next call 13 (opening in the first half of 2024), no DiPOLE XRD proposals will be accepted in favor of DAC proposals.
- Please note that this does not apply to DiPOLE proposals at lower photon energies for IC1.

Community effort to bring DiPOLE laser to IC1, aka „EUXFEL DiPOLE eV spectroscopy community proposal “

- In this run, **one** community proposal will be open for submission for performing the first shock compression experiment with DiPOLE in the IC1 chamber.
- The spokesperson (Main Proposer) is **Dominik Kraus** (Univ. Rostock), email: dominik.kraus@uni-rostock.de
- The Principle Investigator is **Thomas R. Preston** from HED, European XFEL email: thomas.preston@xfel.eu
- The pre-agreed local contact is **Oliver Humphries** from HED (oliver.humphries@xfel.eu)
- This experiment will likely use seeded beam (1 eV bandwidth) at 8.3 keV and concentrate on
 - Resonant inelastic X-ray scattering (RIXS)
 - X-ray emission spectroscopy (Fe K-beta)
 - Plasmon dispersion $\omega(k)$
 - X-ray Raman spectroscopy
 - Technical developments
- If you are not part of the proposer group yet and would like to join, please contact Dominik Kraus.
- DiPOLE in IC1 is NOT YET available for regular user experiments. We anticipate to open this platform for general users in the next call 13.

Community effort for the first pulser magnetic field (PMF) experiment at HED-HIBEF

- In this run, **one** community proposal will be open for submission for performing the first pulsed magnetic field experiment at HED-HIBEF.
- For more details, please contact
 - Carsten Baetz (carsten.baetz@xfel.eu) or
 - Cornelius Strohm (cornelius.strohm@desy.de)
- More information will follow here soon.

Standard configuration: DiPOLE XRD in IC2 (18 keV)

“Dynamic laser-compression platform”

Proposals for DiPOLE in IC2 ONLY in this standard configuration

(more complex proposals will be possible in future calls)

> EU call HIREP frame

- Geometry: the quasi-collinear shock geometry (22.5° between shock direction and x-rays), however 90° between laser drive and x-rays may be proposed, but requires a setup change and commissioning time (please account for it in your proposal).
- DiPOLE100-X laser at 2w, focus on target with $250\ \mu\text{m}$ or $500\ \mu\text{m}$ phase plate
- 2w (green) laser energy: temporal square pulse scales as currently expected: ca. 50 J in 10 ns, ca. 15 J in 2 ns.
- pulse shaping (other than flattop) on best-effort basis, contained energy has to be evaluated and will be lower than in a square pulse.
- X-ray diagnostics: XRD with VAREX at 18 keV x-ray photon energy, SASE.
- Optical diagnostics: VISAR (1 arm 1064nm and 2 arms 532nm) plus 1 SOP arm.

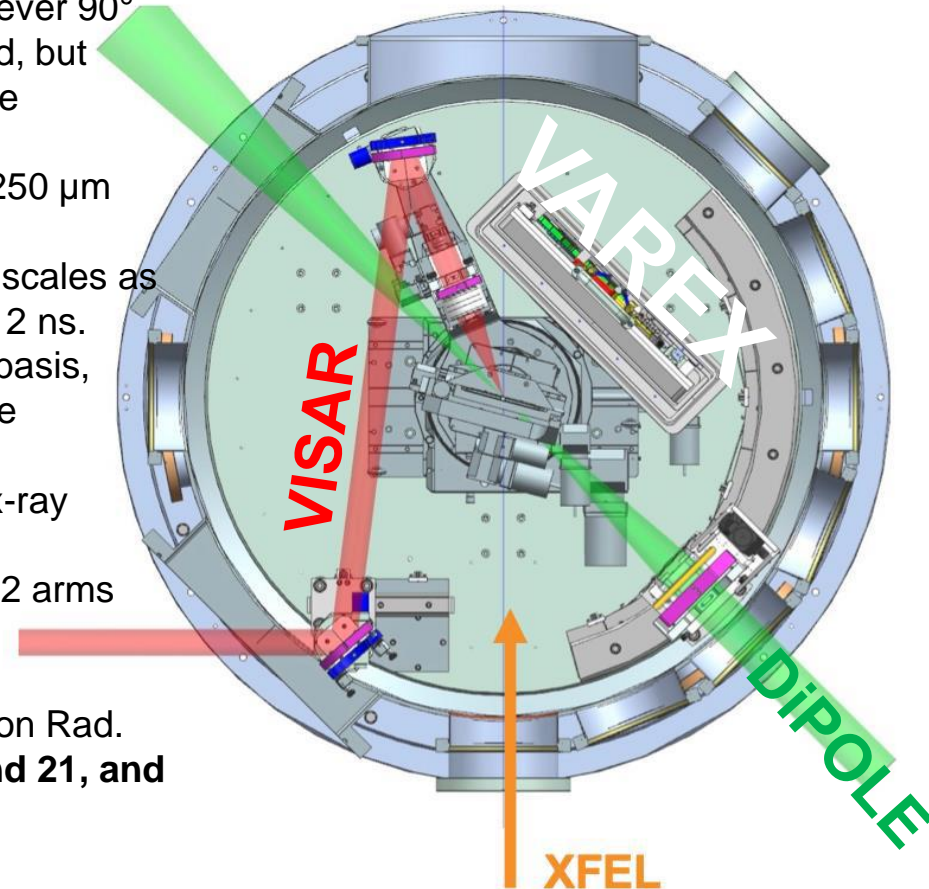

For more details, refer to Zastrau et al., J. Synchrotron Rad. (2021). 28, 1393–1416, **chapter 6.4.2, figure 20 and 21, and for VAREX chapter 6.4.4.**

2 Standard configurations for RELAX experiments

ReLaX standard configuration 1: ReLaX + SAXS + PCI + Spectroscopy

IC1 chamber, 100 TW ReLaX laser incident on target at 45° w. r. t. XFEL
(no normal incidence of laser on target)

SAXS+PCI @ 8.15 keV SASE (slightly flexible, minimum 7.5 keV), ca. 1 mJ per pulse, 2.25 MHz maximum rep rate.

- 5-50 μm spot size (both X-ray and ReLaX)
note that $>10 \mu\text{m}$ spot by defocusing of off-axis parabola will produce non-homogeneous spatial profile
- PCI resolution of about 1 μm
- X-ray spectrometers:
Backward HAPG x-ray spectrometer.
Forward spectrometer with restrictions due to SAXS setup.

Note that the spectroscopy signal may suffer from plasma background, which would require e.g. special shielding. Please contact HED staff for details before submission.

Laser diagnostics (upon request):

- EMP, electron, bremsstrahlung and proton diagnostics
(contact HED staff for details before submission).

2 Standard configurations for RELAX experiments

ReLaX standard configuration 2: ReLaX + Imaging + Spectroscopy

IC1 chamber, 100 TW ReLaX laser incident on target at 45° w. r. t. XFEL
(no normal incidence of laser on target)

Imaging @ 8.15 keV SASE (slightly flexible, minimum 7.5 keV), ca. 1 mJ per pulse, 2.25 MHz maximum rep rate.

- 1.5-50 μm spot size (X-ray),
- 5-50 μm spot size ReLaX)
note that >10 μm spot by defocusing of off-axis parabola will produce non-homogeneous spatial profile
- Imaging resolution <1 μm

Not compatible with SAXS

Backward and forward HAPG x-ray spectrometer. Note that the spectroscopy signal may suffer from plasma background, which would require e.g. special shielding. Please contact HED staff for details before submission.

Laser diagnostics (upon request):

- EMP, electron, bremsstrahlung and proton diagnostics
(contact HED staff for details before submission).

Platforms – Interaction Chamber 1

- 2 ePIX100 detectors for spectroscopy, imaging or XRD, 50um pixel pitch, ~700x700 pixels, 10 Hz. Very low noise – **currently damaged!**
- 4x (vacuum) and 1 in-air JUNGFRU detectors (gain switching 10^4) at 10 Hz (**no** burst mode) for XRD or spectroscopy (pixel pitch 75um, detector size ~ 3.5*7 cm)

For details on detectors,

please contact Thomas Preston (Thomas.preston@xfel.eu) from EuXFEL HED/detector group.

- Possibility to mount area detectors or spectrometers on curved rails in vacuum on vertical breadboard
- Von-Hamos HAPG spectrometers (RoC 50mm and 80mm, crystals available 40um HAPG, 100um HAPG, 200um HOPG)
- X-ray emission spectroscopy in Von-Hamos geometry
- High-resolution monochromator and diced analyzers (Si 533) for ~45meV spectroscopy at 7.490 eV
- stepper-motor target stage (10x10 cm area) on hexapod and precision rotation stage
- CRL4 for ~ μ m foci with short focal length

Cryogenic liquid jet target platform IC1

The platform features:

Contact: Sebastian Göde

- Vertical jet flow direction
- Nozzle types: round and slit (size/shape depends on gas type)
- Gas types: Hydrogen (tested), Methane, Argon and others (not yet commissioned with the setup)
- Motorized target rotation +/-45 deg (z-axis)
- High resolution on-shot target imaging (xy-plane)
- Online target position recognition (see screenshot)
- Compatible with FSPEC, BSPEC, SAXS, XRD diagnostics in IC1
- 30x30mm target frame (calibration, pin, ref targets, etc.)
- High repetition rate shots with ReLax and PP lasers (possible laser parameters are jet type dependent)

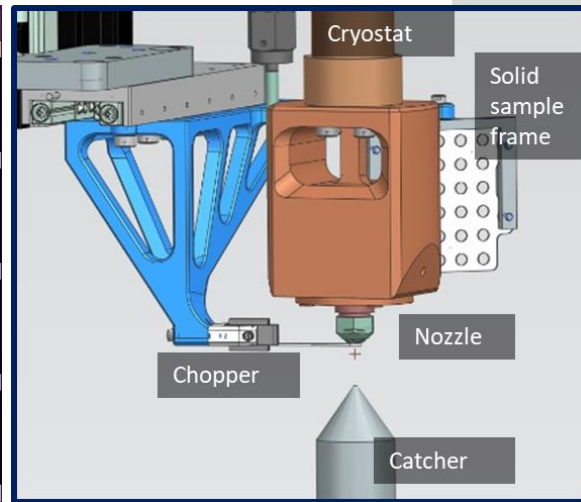
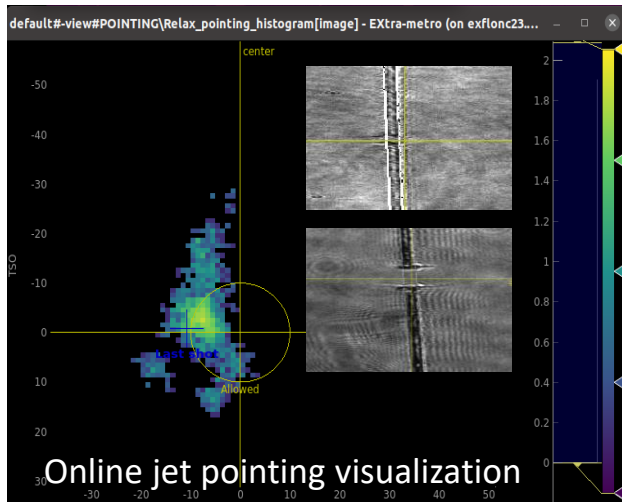
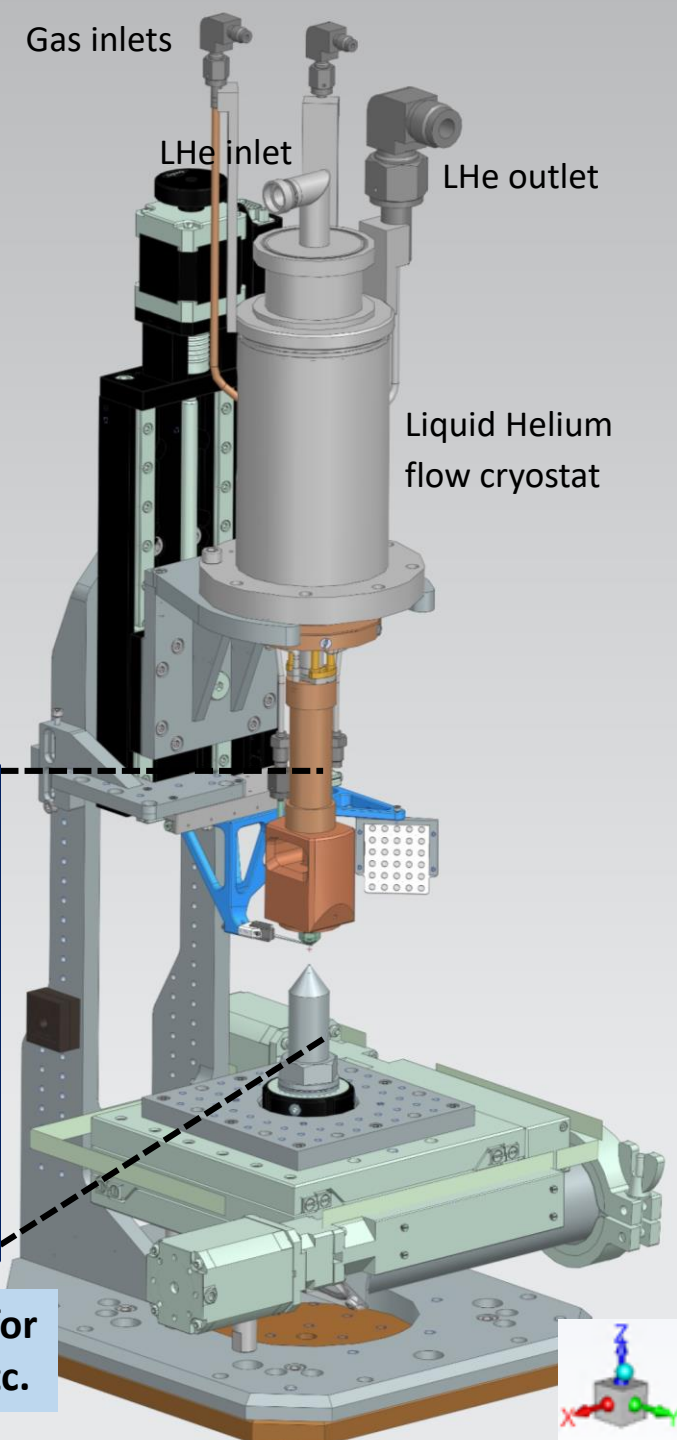

Before submitting proposals, please discuss with beamline contact for possible geometries, other x-ray diagnostics, target & laser specs, etc.



Platforms – Interaction Chamber 2

■ IC2 (alternating setups)

- Diamond Anvil Cell (DAC) setup for precision XRD
- AGIPD mini-half 4.5 MHz detector
- Pulsed laser heating for DAC research
- Dynamic DAC (dDAC)

- DiPOLE XRD shock setup
- 2 VAREX flatpanel detectors in IC2 (10 Hz)
- VISAR

IC2:

a) outside

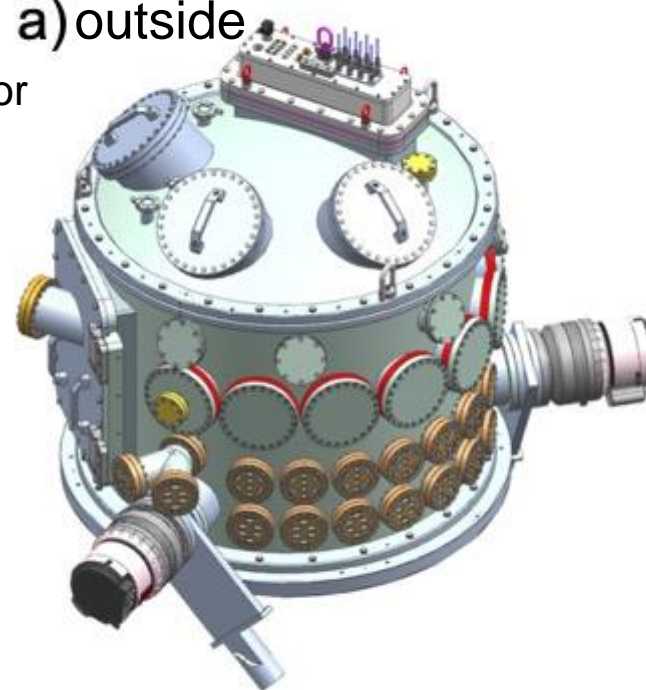

b) inside

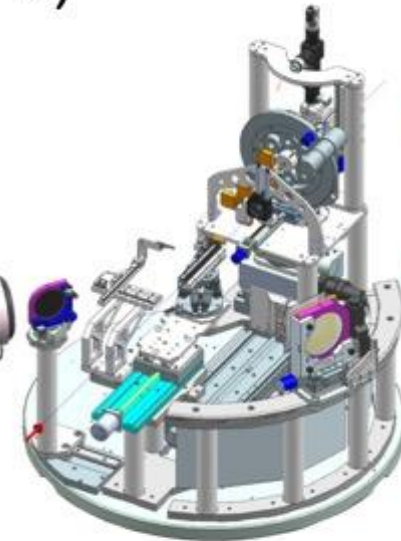

contact HED instrument scientists: *Zuzana Konopkova*,
or HiBEF UC members: *Cornelius Strohm*, *Rachel Husband*
for details of this platform

Platforms – Interaction Chamber 2 + shock setup

IC2

Shock-setup in IC2

Can be coupled with 1030 nm pp-laser with ~450 ps duration (see slide 27)

Other possibilities (other pump laser sources) need to be discussed with instrument scientists before submission.

Only in 18keV standard configuration.

IC2

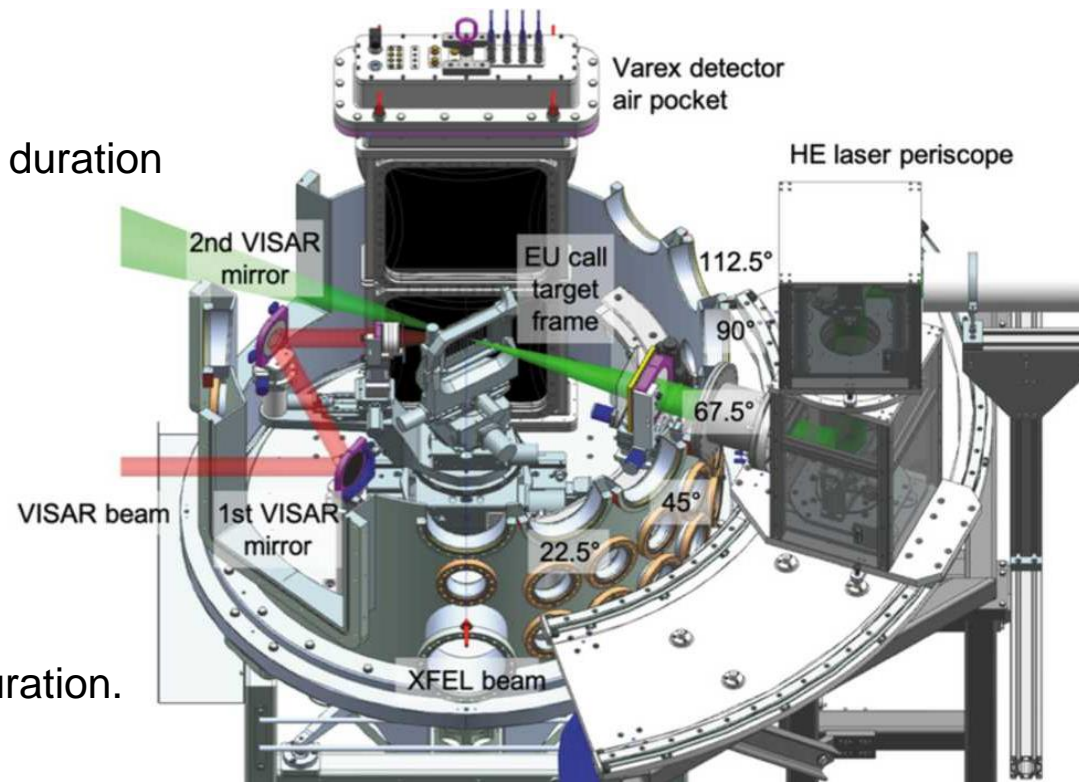

X-ray delivery from the facility to HED

The conditions expected for this allocation period are listed below. **Nevertheless, case-by-case verification of specific feasibility conditions with the instrument groups is required.**

	Photon energy range	Expected pulse energy**
SA2	5.8–9.3 keV	2 mJ
	>9.3–12 keV	1 mJ
	>12–24 keV	0.5 mJ

Bunch distribution: 350 X-ray pulses per instrument assuming the equal distribution at 2.25 MHz. Higher or smaller numbers for higher/smaller intra-train frequency.
Max. 2250 electron bunches within 500 μ s at 4.5 MHz (only 1 week in the next run).

** Pulse energy depends on bunch charge, electron energy, and photon energy.

The above parameters correspond to the *standard* SASE operation mode.

The following *special* modes are available but require more tuning and are less reliable:

- Hard X-ray self-seeding (SA2; 7 - 14 keV)
- Hard X-ray two-colour w. variable delay (SA2; 6–10 keV; 0–0.5 ps)
- Short bunches (< 10 fs FWHM); requires coordinated scheduling as other instruments and available number of bunches might be affected; time-diagnostics is only partially available
- Full trains at instruments with rep. rates much lower than 10 Hz (~ max. 2250 pulses)

Experiments requesting these *special* modes should address the development of new techniques and fields and are expected to involve large communities and facility staff. Since there is a vast range of detailed specifications for these special modes, proposers are requested to **contact instrument staff before submission** in order to clarify requirements.

Details on Special mode d: Full trains with low rep rates (up to ~2250 pulses)

- EuXFELs timing system is absolutely capable of this mode. However the various feed-backs and feed-forwards that are presently optimised for each beamline separately will have to work on a common setpoint.
- We would tune for a 'compromise' working point that works for all cases, but would not reconfigure the linac for a single pulse every minute or so. So every SASE would operate with a not optimal working point all the time.
- As a consequence we estimate a systematic **about 30% less intensity at compared to the standard modes.**
- The accelerator would run normally, where each train would deliver a portion of the RF window to each SASE. Then, every minute or so, a full train (full RF window) would go ONLY to SASE2 (HED). This means that SA1 and SA3 would “miss” one train every minute.

Some constraints

- The linac of EuXFEL has specific electron energy setpoints, 11.5, 14, and 16.5 GeV.
- At 11.5 GeV, the available photon energy range at SASE2 and HED is 5-9 keV, it can be extended to higher values but the intensity will drop significantly. Even at 8-9 keV, the pulse energies will probably not exceed 0.3 mJ. 14 GeV: ~6 - ~ 15 keV, 16.5 GeV: 8.2 – 25 keV, respectively.
- It is **not possible to change between 5-6 keV and 12-24 keV** during one user experiment because the electron energy is fixed for the entire facility.
- We **strongly recommend to not change the photon energy during your experiment**, or at least not more than 1 keV. Larger changes need extensive tuning time of the LINAC and undulators and may lead to a low technical feasibility ranking. Also the x-ray focusing needs to be changed and aligned after each change.
- In **HXRSS (seeding mode)**, it is not possible to scan the photon energy wider than the SASE bandwidth, i.e. ~30 eV at ~10 keV photon energy
- The „**special mode**“ **two-color** (see slide 3) has been successfully used at HED in 2022, however interested proposers should contact HED staff with their specific request and HED would catalyze a discussion with experts feeling comfortable to discuss these. We feel confident to offer up to 100 µJ per color and pulse.

X-ray parameters and diagnostics for the HED instrument

- ❑ 5-24 keV x-ray photon energy SASE spectrum (about 0.2..0.3 % bandwidth), usually about 1-2 mJ pulse energy in ~20-40 eV bandwidth
- ❑ Seeded x-rays between 7-14 keV (~1 eV spectral width), few 100 μ J

- ❑ Single pulses/trains on demand, or 10 Hz continuous
- ❑ pulse trains of 2.25 MHz (440 ns) or less (down to single pulse on demand)
- ❑ One week with 4.5 MHz rep. rate (222 ns pulse spacing)

- ❑ *Only experts:* 4-bounce monochromator (1 eV bandwidth) at max. 10 Hz between 5-18 keV *please contact Karen Appel before to talk about transmission and stability.*
- ❑ High resolution-mono@7.49 keV (about 40 meV bandwidth) at 10 Hz

- ❑ full focusing capability CRL 1,2,3,4
any focus from parallel beam (few μ rad divergence) down to slightly less than 1 μ m foci, however with potentially significant absorption in the Be lenses. **The feasibility of sub-micron foci at any photon energy has to be discussed with the instrument scientists before submission.**

- ❑ “HIREX2” spectrometer in the SASE2 branch (before the separation into MID and HED) for monitoring the incident SASE / seeded spectrum.

HED beam transport

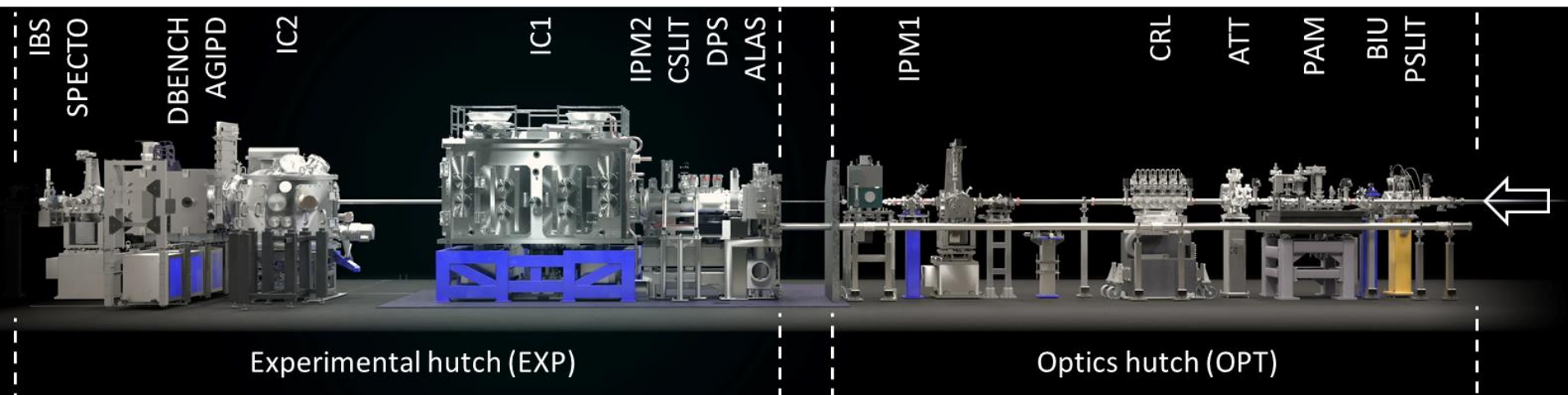

5x5 μm focus characterized

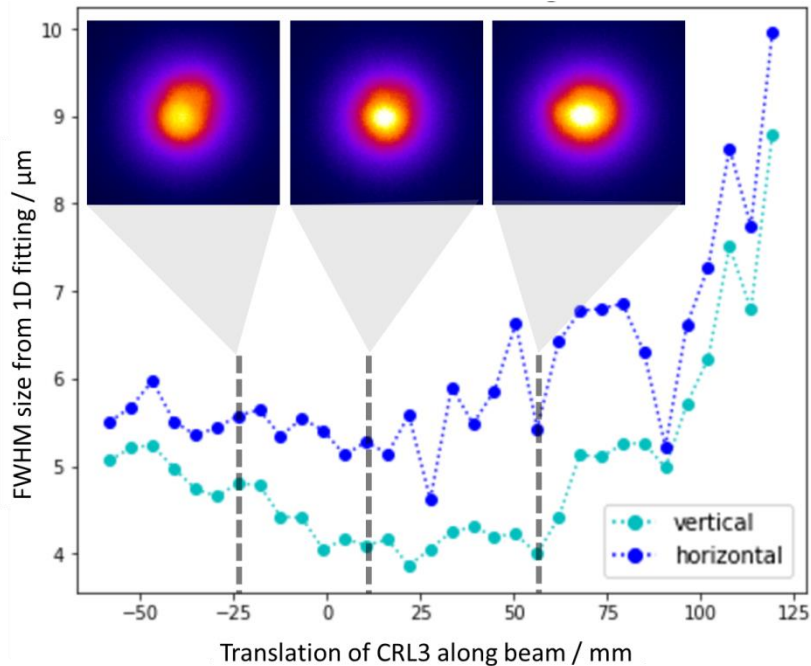

Focus in IC1 at 6.0 keV photon energy
by LiF imprints and post analysis

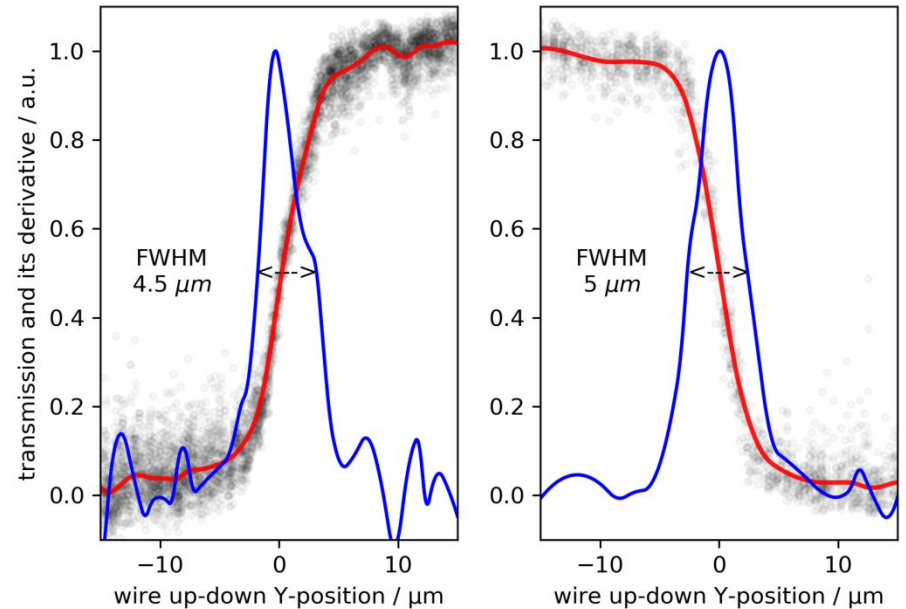

Focus in IC2 at 17.8 keV photon energy
by scanning with a 1 mm diam. W rod

ePIX and JUNGFRAU

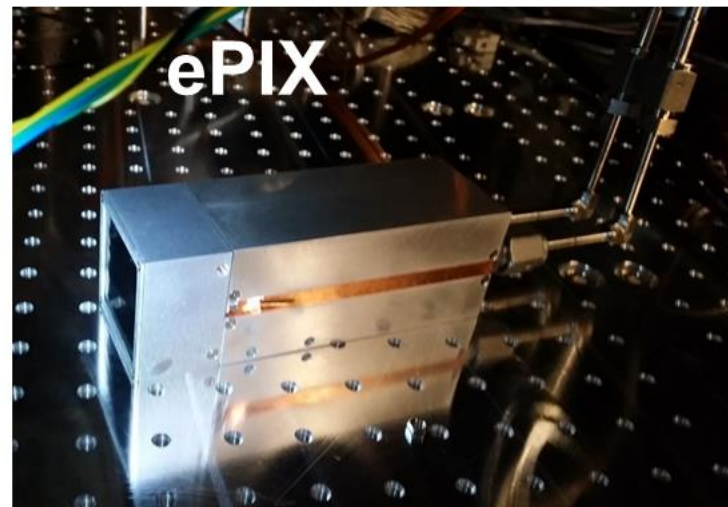

Name	Pixel size (μm)	No. of pixels (adim.)	Detection area (mm^2)	Noise (eV)	Frame rate (Hz)	Dynamic Range (photons per pixel)
ePix 100	50	704×768	35×38	< 280	120	10^2 8 keV
Jungfrau	75	512×1024	38.55×77.25	< 450	2400	10^4 12 keV

Mosaic graphite von-Hamos spectrometer

- Inside IC1, we offer von-Hamos HAPG spectrometers for emission or scattering experiments. Please contact us for further details. A JINST publication is available: <https://doi.org/10.1088/1748-0221/15/11/P11033> .
Contact Thomas Preston for details.
- The spectrometers, equipped with Jungfrau detectors and tungsten shielding, have been successfully used for K-line spectroscopy in combination with RELAX shots at $I=10^{20}$ W/cm².

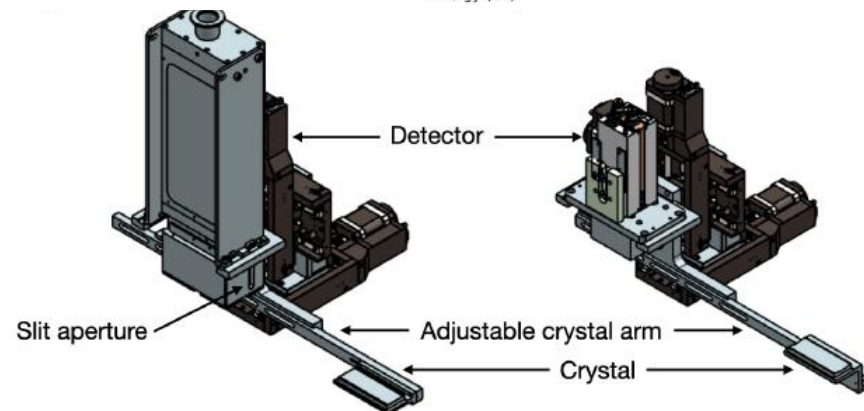
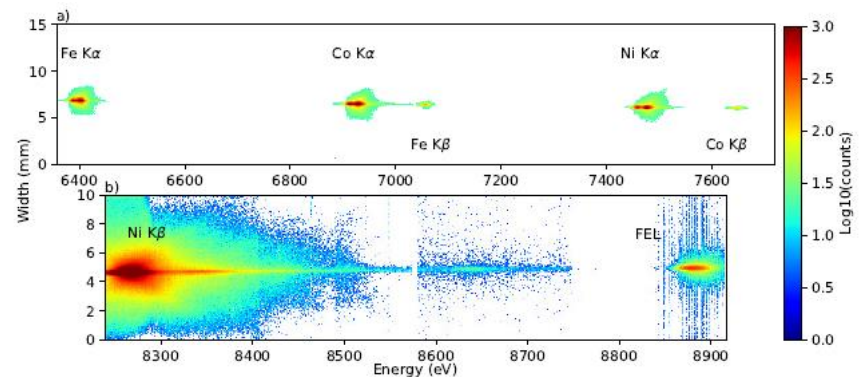
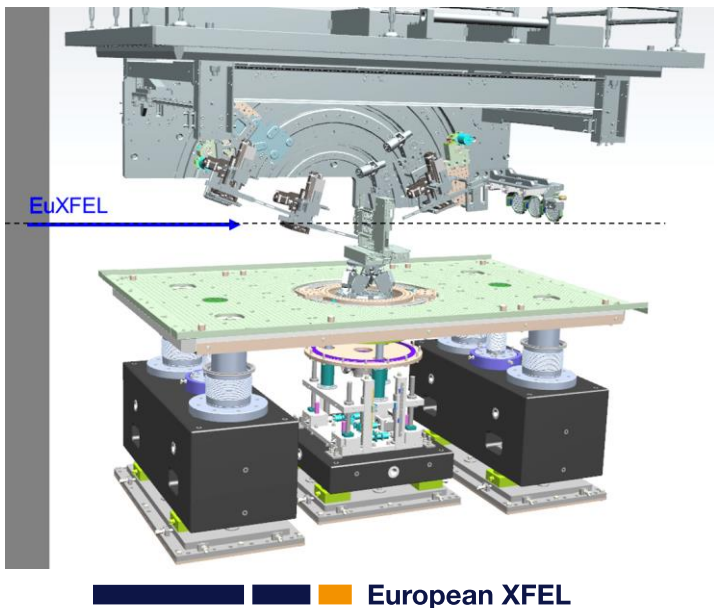

High res-IXS: Instrument function

Descamps et al., Scientific Reports 10, 14564 (2020)

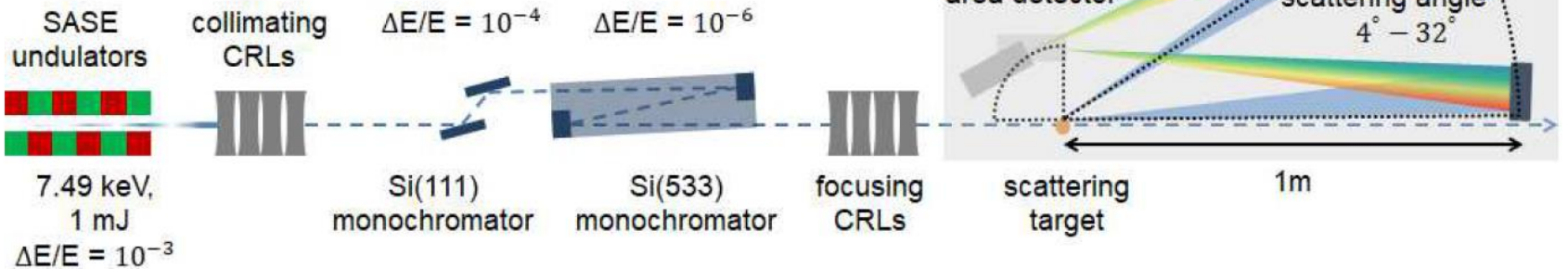

Samples thickness ~
 pixel size yield
 close-to design
 spectral resolution

Wollenweber et al.,
 Review of Scientific Instruments
 92, 013101 (2021)

Contact Karen Appel or
 Thomas Preston for details.

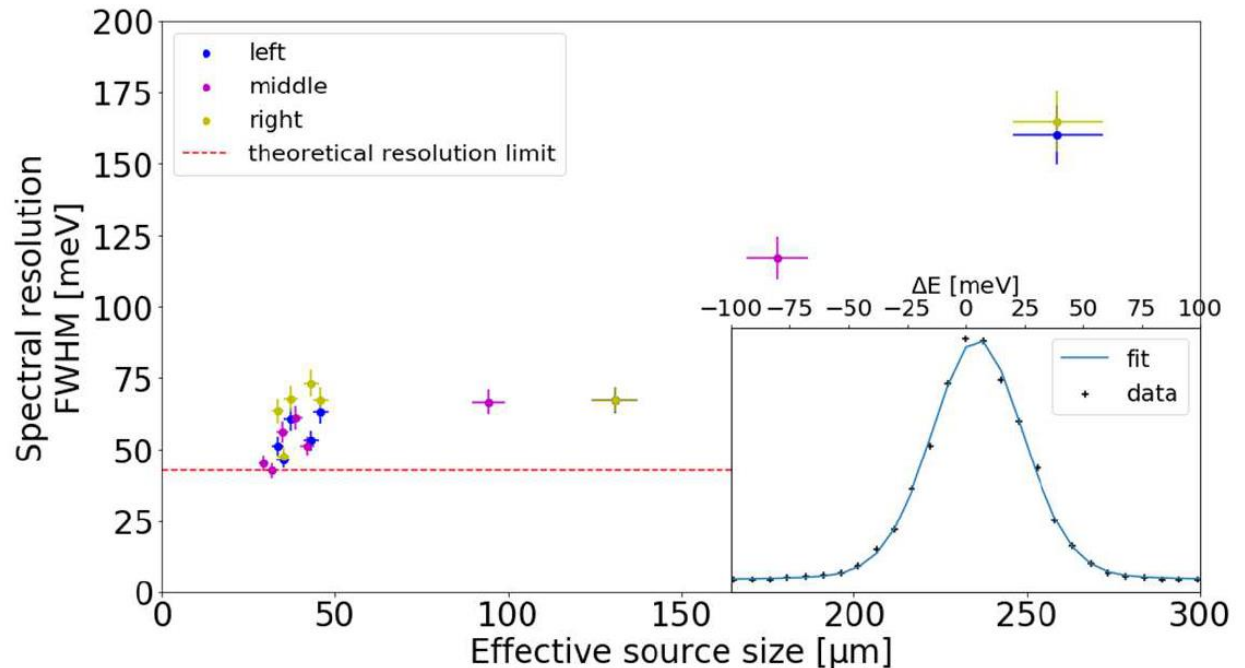
“direct”-beam spectrometer, AGIPD detector

- ❑ bent diamond crystal spectrum analyzer downstream of the interaction.
Contact Karen Appel for details if you plan to use it.
- ❑ AGIPD 500K detector (352 images at 3 gain stages with up to 4.5 MHz).
Contact Cornelius Strohm for details. It is part of the DAC platform.

AGIPD 500K

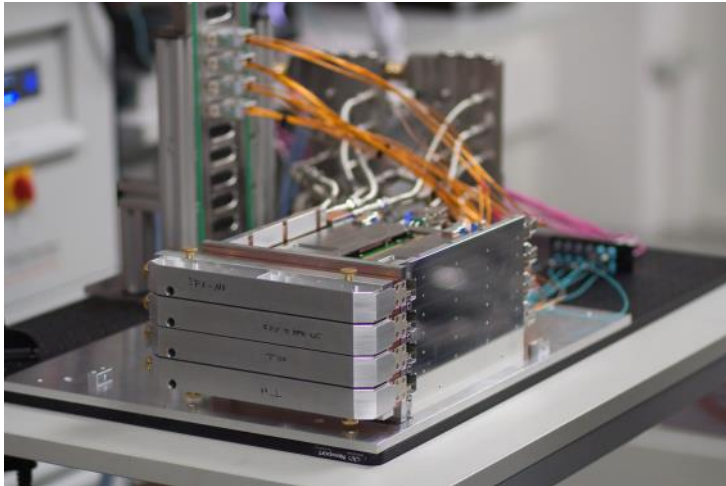

XRD standard on the AGIPD 500K at HED -
LaB6 at 17.8 keV

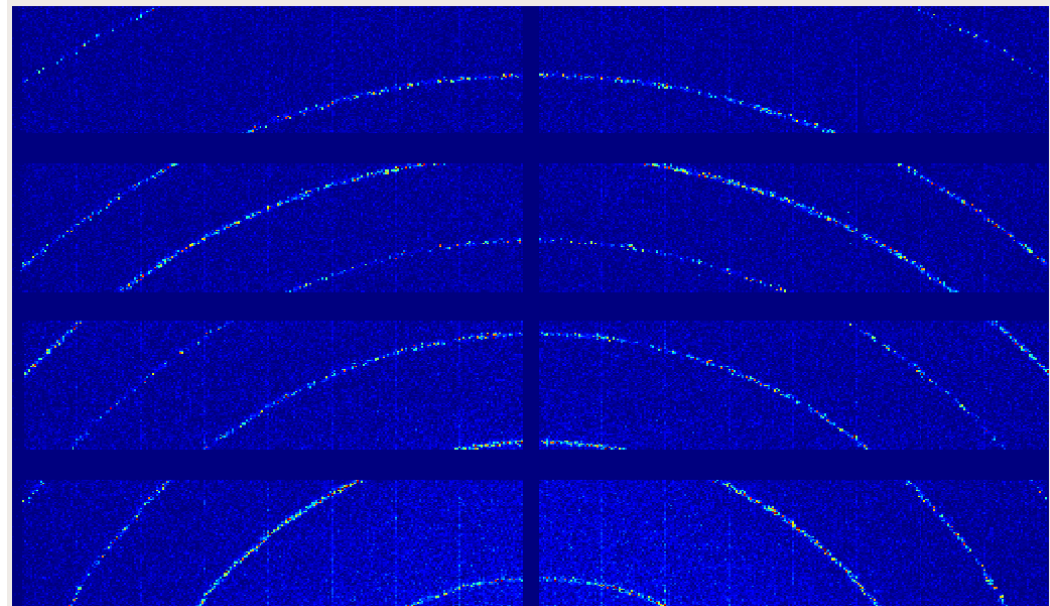

Pulsed Laser heating for DAC research

- double side laser heating in DACs
- 2x 100 W NIR lasers in pulse mode or cw mode
Pulse duration 10-500 ns, and >1 μ s possible
- temperature determination: time resolved spectral radiometry (SOP) using camera system

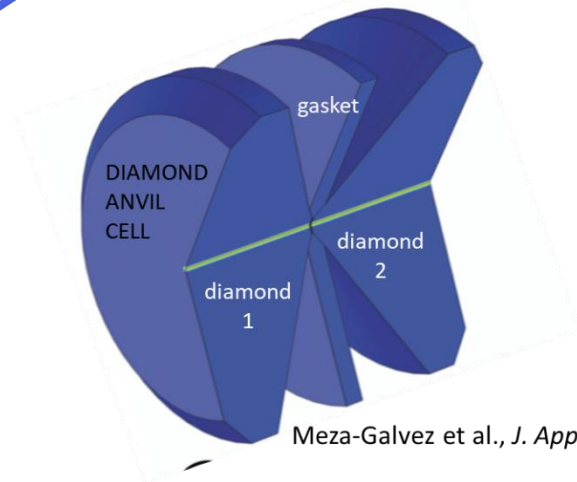
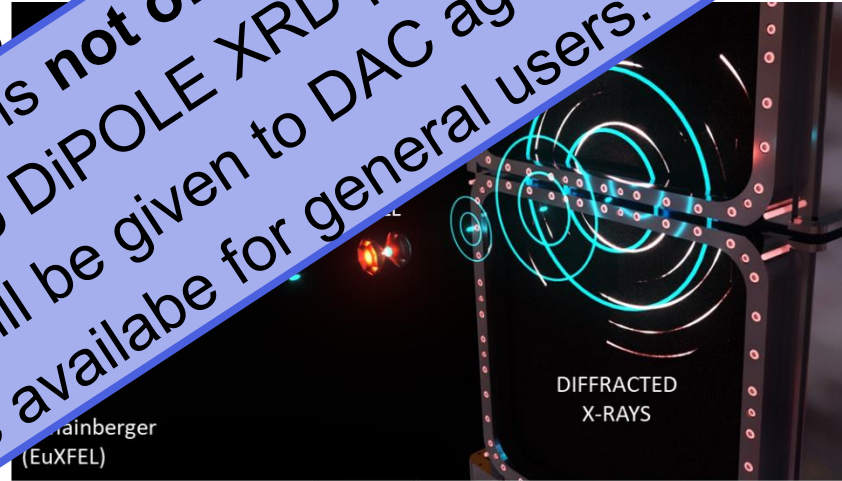

Meza-Galvez et al., *J. App. Phys.*, 2020

NOTE: In Call 12, the DAC setup in IC2 is not offered for regular user experiments. Priority is given to DiPOLE XRD proposals instead. In the next call 13, priority will be given to DAC again, and DiPOLE XRD in IC2 will not be available for general users.

...a@xfel.eu

Streak Optical Pyrometry (SOP) to measure thermal emission

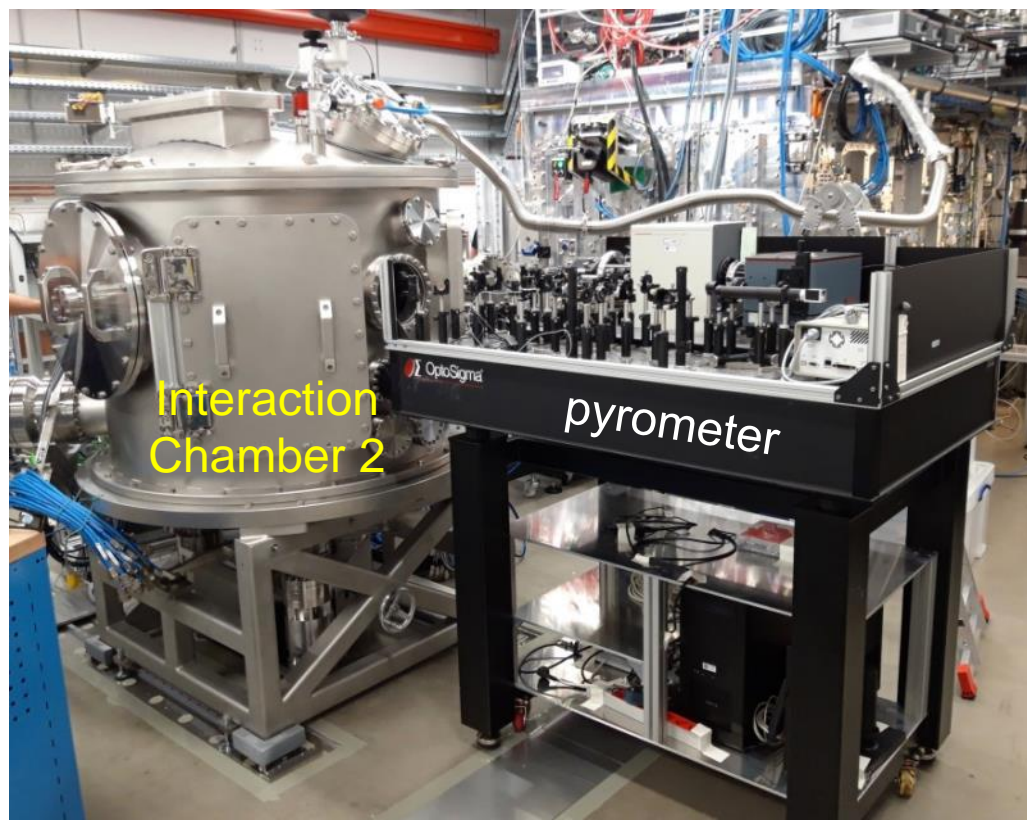

Streaked spectrogram

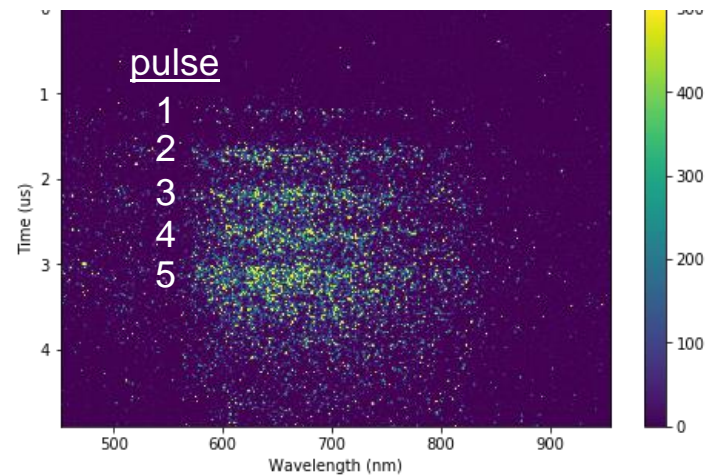

*For further information, please contact Zuzana Konopkova from the HED team:
zuzana.konopkova@xfel.eu*

Von-Hamos spectrometer for measurements from DACs in IC1

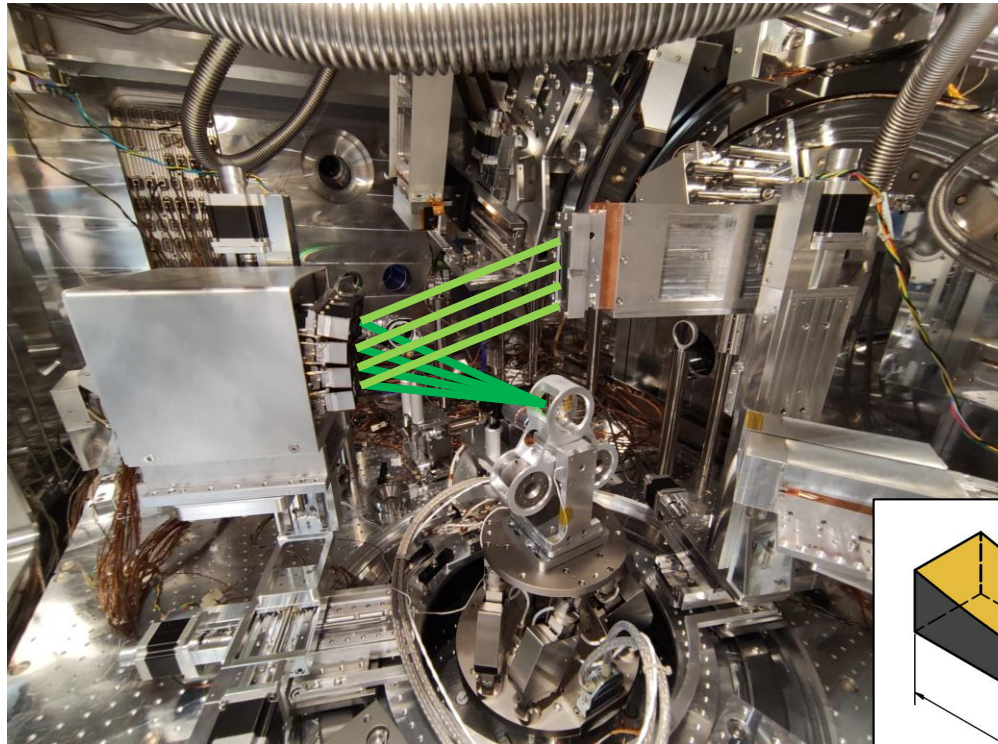

Courtesy J. Kaa

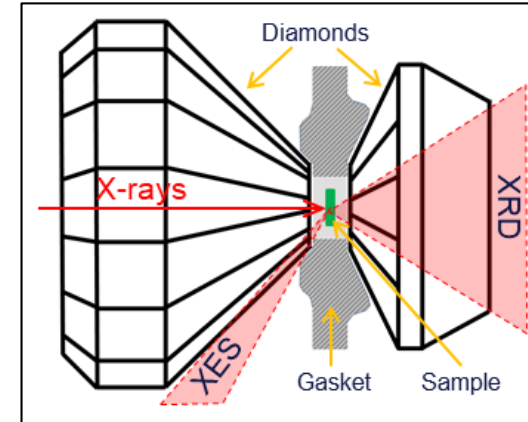

Kaa et al. 2023, accepted

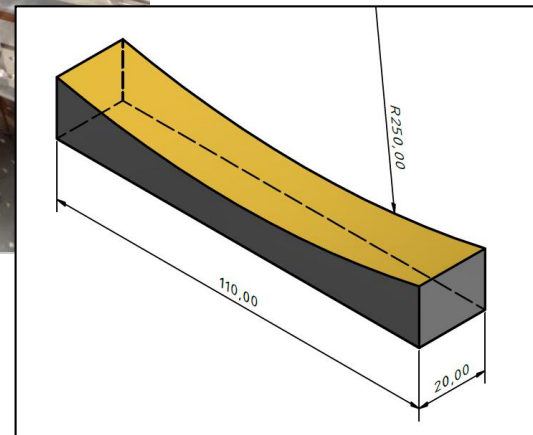

- range: 6 keV - 12 keV
 dispersion: ~0.4 eV/pixel (JF detector)
 instrumental broadening: ~0.5 - 1 eV

■ Multi-fluorescence spectroscopy e.g.:

- Si(531) for Fe K beta
- Si(333) for Fe K alpha
- Si(444) for Re L alpha (~12 keV)

Crystal	Orientation (hkl)	d-spacing (Å)
Si	531	0.9179
Si	111	3.1355
Si	533	0.8281
Si	511	1.0451
Ge	220	2.0000
Ge	111	3.2660

Pump-probe (PP) laser

■ Anticipated parameters

■ PP laser at 800 nm wavelength

- ▶ < 20 or 50 fs duration, close to Fourier-limited bandwidth (going for narrower bandwidth with longer pulse duration is an option)
- ▶ max ~2 mJ at 100 kHz, or down to 10Hz or shot-on-demand
- ▶ Higher repetition up to 4.5 MHz with lower pulse energy
- ▶ Second harmonic (400 nm) is available. Conversion efficiency is however low (15-20%) due to the large bandwidth.
- ▶ Chirped mode up to ~10 ps duration

■ PP laser at 1030 nm wavelength

- ▶ Duration: ~ 1 ps compressed “or” ~450 ps uncompressed.
 - *Please contact instrument scientists to discuss the possibility of pulse durations in between these two values.*
- ▶ max ~30 mJ at 100 kHz, or down to 10Hz or shot-on-demand
- ▶ Higher repetition up to 4.5 MHz with lower pulse energy
- ▶ Second/third harmonic (515/343 nm) are *potentially* available.

If you plan to use the PP laser, please contact Motoaki Nakatsutsumi from the HED team to discuss your requirements:

motoaki.nakatsutsumi@xfel.eu

HI-OL: HiBEF ReLaX TW laser

There is a publication about the performance of this laser:

High Power Laser Science and Engineering

A. Laso Garcia et al., High Power Laser Science and Engineering (2021) - <https://doi.org/10.1017/hpl.2021.47>

Further questions about the laser can be directed to Toma Toncian, t.toncian@hzdr.de

HI-OL Laser parameters:

- up to 100 TW laser beam available at IC1 target chamber.
- Laser pulse duration <30 fs (nominal).
- Energy up to 3 J on target.
- Irradiation geometry: 45 deg to X-ray axis and target normal.
- F/2 focusing optic.
- Laser wavelength 750-850 nm.
- Arrival jitter compared to x-rays at IC1 <30 fs RMS.
- a synchronized optical probe beam with mJ energy can be made available upon request.
- on shot diagnostic package with NF, FF, WF, pulse duration, arrival time at PAM.
- latest laser contrast trace can be measured upon request.
- Shot-on-demand experiments (other modes upon request).

Shot rate will be limited by alignment time, debris issues, and probationary radiological limits.

For further details, contact Toma Toncian: toma.toncian@xfel.eu

HI-OL: HiBEF ReLaX TW laser standard configuration 1: SAXS + PCI + Spectroscopy

X-ray diagnostics:

- X-ray XFEL photon energy: **SASE, 7.8...9 keV**
- X-ray spectrometers (HAPG)
- Small angle scattering (SAXS) setup
 - angular range covered: 1.7-19 mrad
 - indirect FOV imaged with Highly Oriented Pyrolytic Graphite Crystals
 - with an accepted x-ray bandwidth optimized for 8.15 keV
- Focusing setup (CRL3)
 - direct FOV: $10^2 \mu\text{m}^2$ to $1000^2 \mu\text{m}^2$

Non X-ray diagnostics can be provided if needed:

- Thomson Parabola with an energy range .5- 40 MeV for p+
- electron spectrometer
- Bremsstrahlung spectrometer with an energy range up to 20 MeV

"Other diagnostics (e.g. optical probe such as FDI) can be discussed and integrated in the proposal upon request if feasible."

HI-OL: HiBEF ReLaX TW laser standard configuration 2: Imaging + Spectroscopy

X-ray diagnostics:

- X-ray XFEL photon energy: **SASE, 7.8...9 keV**
- X-ray spectrometers (HAPG)
- Focusing setup CRL4a inside the chamber before target
FOV: $1.5^2 \mu\text{m}^2$ to $50^2 \mu\text{m}^2$

- Imaging setup CRL4b inside the chamber after target
FOV: 200^2 to $400^2 \mu\text{m}^2$

Non X-ray diagnostics can be provided if needed:

- Thomson Parabola with an energy range .5- 40 MeV for p+
- electron spectrometer
- Bremsstrahlung spectrometer with an energy range up to 20 MeV

"Other diagnostics (e.g. optical probe such as FDI) can be discussed and integrated in the proposal upon request if feasible."

THIS CONFIGURATION IS NOT COMPATIBLE WITH STANDARD CONFIGURATION 1!

Typical setup at IC1 combining ReLaX with SAXS, PCI and spectroscopy

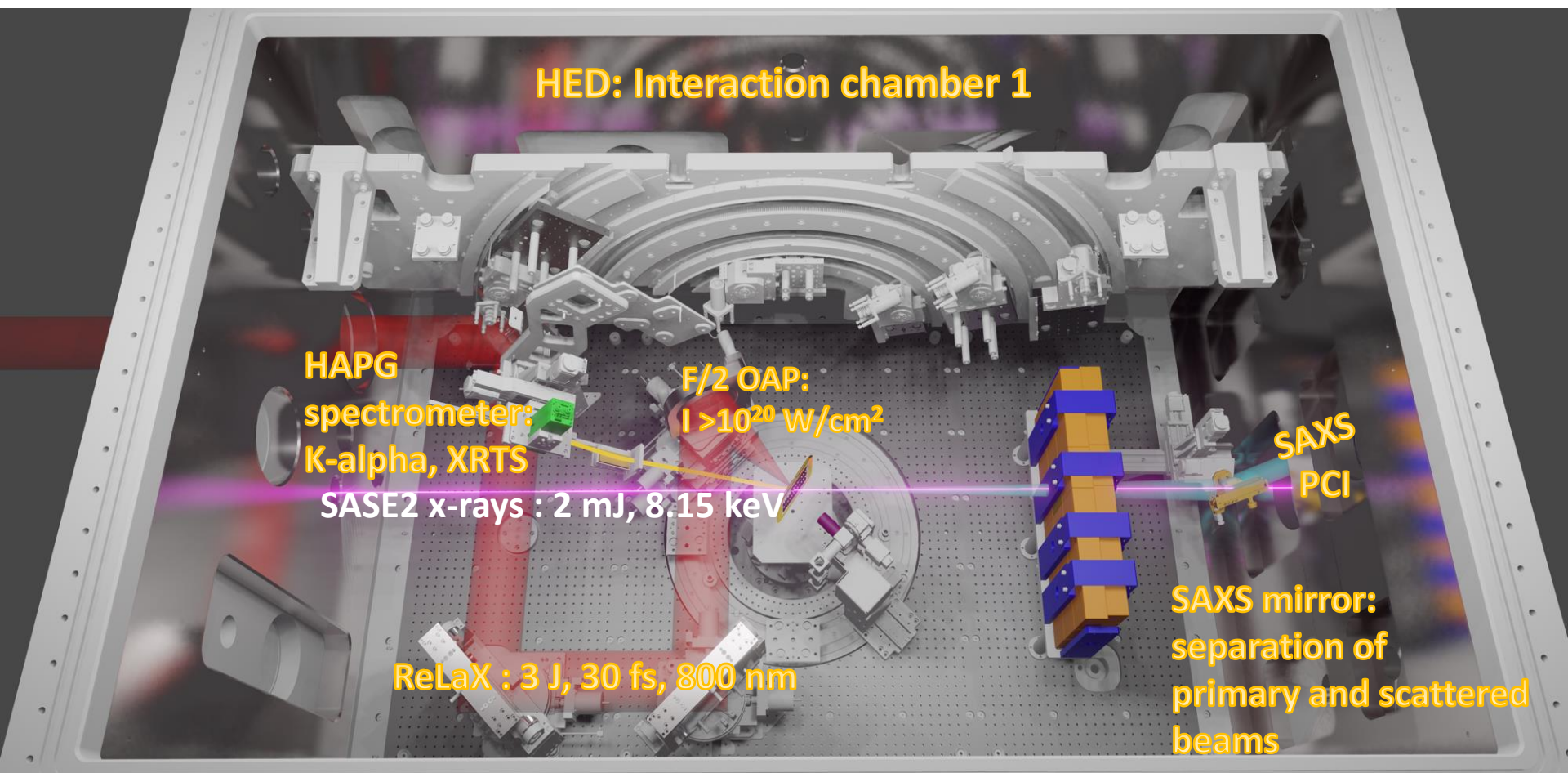

Pulse-to-pulse arrival jitter between x-ray and optical lasers is 20-30 fs

Pump-probe laser

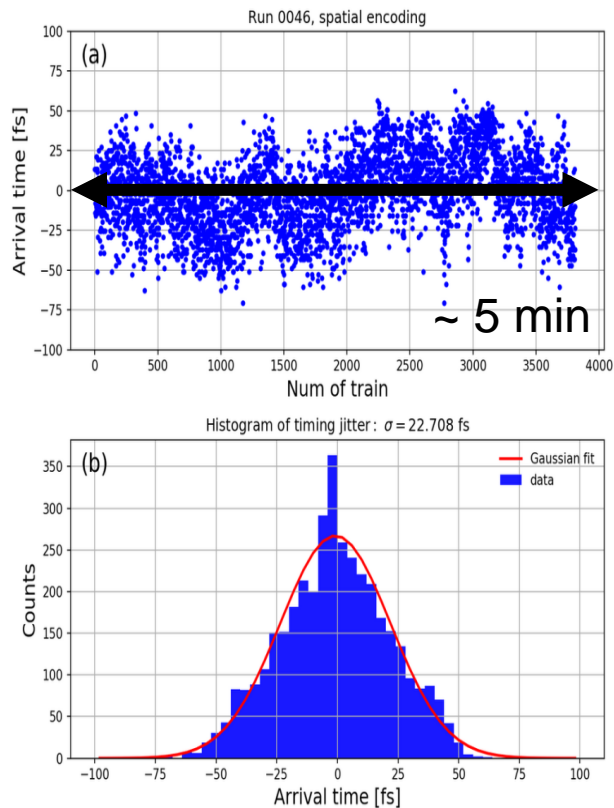

ReLaX TW laser

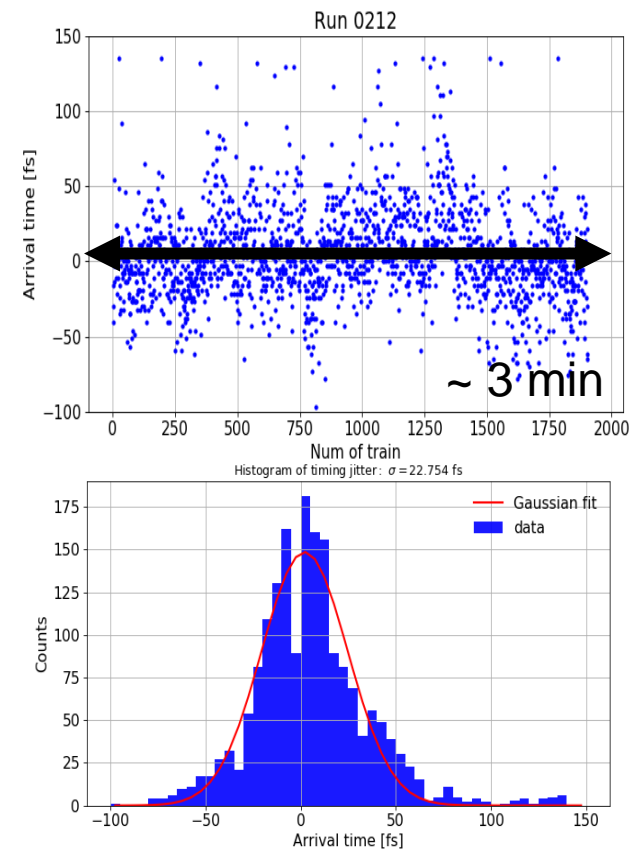

Awareness – beam jitter

Our facility is still suffering from spatial drifts (on the timescale of minutes) and jitter (pulse-to-pulse) of the x-ray beam. It is dominantly in the horizontal direction (left-right). This occurs only sometimes and at unforeseeable times (no correlations with external events). The issue is complex and the root cause(s) not yet fully understood. We are working on solving this issue.



However, from the current perspective, we cannot guarantee that we will have implemented a solution at the time of allocation of your beamtime. Therefore, if your experiment is critically depending on a stable beam pointing, please **address mitigation scenarios** in your proposal, take into account that **more statistics** on your data will be needed, and make your experiment design **robust against beam jitter (e.g. choice of x-ray focusing scheme)**.

This is work in progress - in case of specific questions, please inquire with the instrument scientists.

Instrument papers

General overview of the HED instrument

- Zastrau, Appel, Baehz et al., *J. Synchrotron Rad.* (2021). 28, 1393–1416

DAC research

- Diffraction from Diamond Anvil Cell platform at HED - overview
 - *Liermann et al., JSR (2021). 28, 688-706*
- MHz XFEL XRD and modeling of pulsed laser heated DAC
 - *N. Jaisle et al., J. Appl. Phys. 134 (9), 095904 (2023) – <https://doi.org/10.1063/5.0149836>*
- MHz XRD set-up for dynamic compression experiments in the diamond anvil cell (dDAC)
 - *R.J. Husband et al., JSR 30 (4), 671–685 (2023), <https://doi.org/10.1107/S1600577523003910>*
- Dynamic optical spectroscopy and pyrometry (SOP) under optical and x-ray laser
 - *O.B. Ball et al., J. Appl. Phys. 134 (5), 055901 (2023), <https://doi.org/10.1063/5.0142196>*
- A von Hámos spectrometer for diamond anvil cell experiments
 - *Kaa et al., JSR 30 (4), 822–830 (2023): <https://doi.org/10.1107/S1600577523003041>*

ReLaX: the HiBEF high-intensity short-pulse laser driver

- A. Laso Garcia et al., *High Power Laser Science and Engineering* (2021) - <https://doi.org/10.1017/hpl.2021.47>

Design and performance of the SAXS HAPG mirror

- Smid et al., *Review of Scientific Instruments* 91, 123501 (2020)

Design and performance of the HAPG von-Hamos spectrometers

- Preston et al., *Journal of Instrumentation*, Volume 15 (2020)

Design and performance of the meV high resolution setup

- Wollenweber et al., *Review of Scientific Instruments* 92, 013101 (2021)