



MAX-PLANCK-GESELLSCHAFT



Max-Planck-Institut  
für Kolloid- und Grenzflächenforschung



HELMHOLTZ  
ZENTRUM BERLIN  
für Materialien und Energie

Matias Bargheer

# Femtosecond X-Ray Diffraction Dynamics on Nanoscale Systems

- What do we want to see? Examples: SRO/STO multilayers.
- Data from Plasma-Sources and FEMTO-slicing (Tests before XFEL)
- Ultrafast generation of stress: electrons and phonons (XFEL heat load)
- Ultrafast magnetostriction (magnon-phonon)

# Team

## University of Potsdam

Wolfram Leitenberger  
Roman Shayduk  
Mareike Kiel  
Peter Gaal  
Daniel Schick  
Steffen Mitzscherling  
André Bojahr  
Marc Herzog  
Matias Bargheer



## MPI für Mikrostrukturphysik

Dietrich Hesse,  
Marin Alexe,  
Ionela Vrejoiu



## Max-Born-Institute MBI:

C. von Korff Schmising  
Z. Ansari  
A. Harpoeth  
F. Zamponi  
M. Woerner  
N. Zhavoronkov  
T. Elsaesser



## Swiss Light Source

Chris J. Milne  
Renske Van der Veen  
Steven L. Johnson



## Financial support

*BMBF, DFG*

# Atomic Movies: Ultrafast XRD

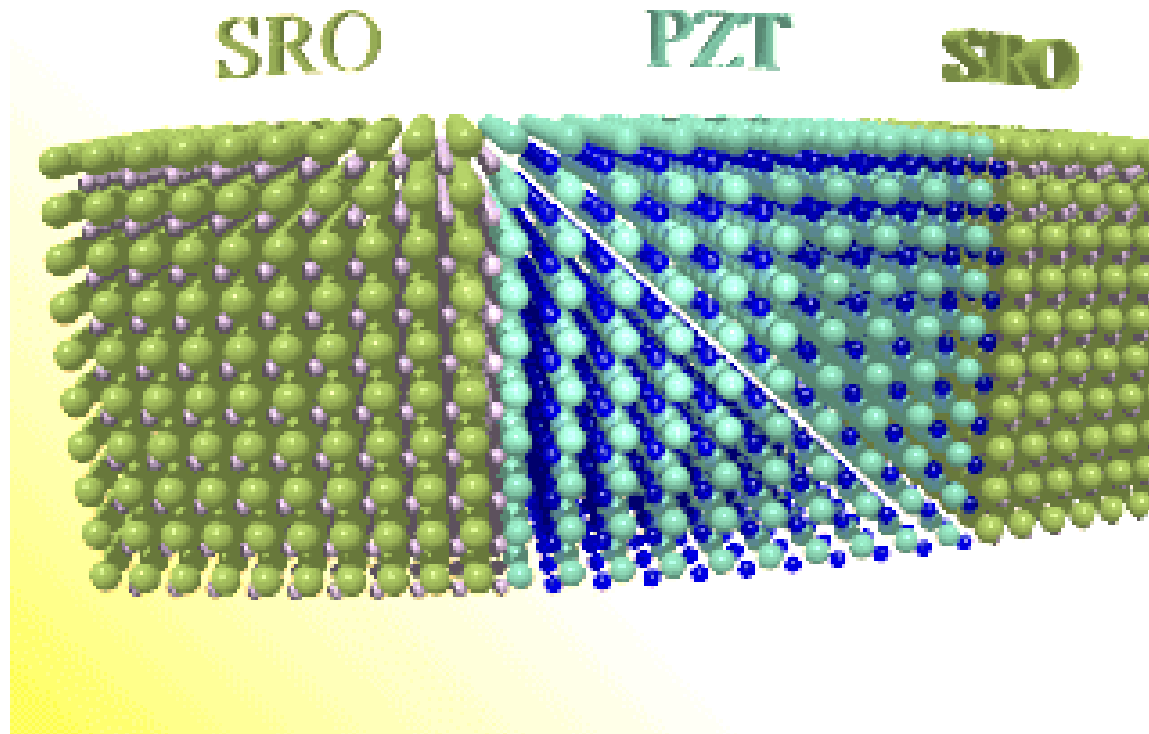

# Microscopic View of Functions and Reactions

## Physics:

- Collective dynamics
- $e^-$  - phonon – interaction

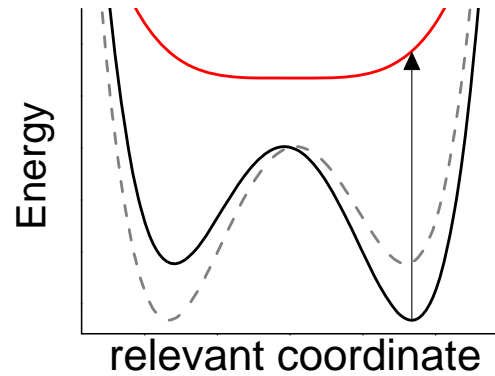
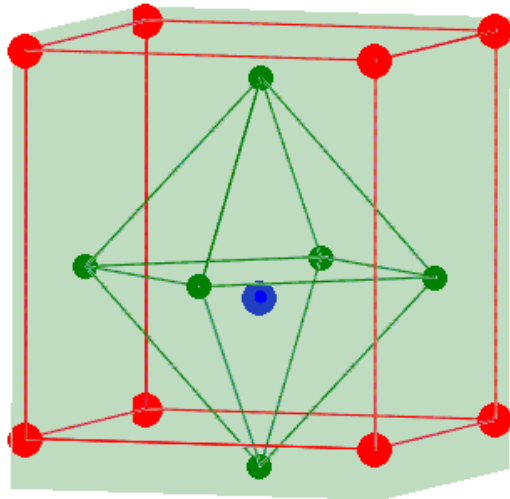

## Soft matter:

- Photobiology

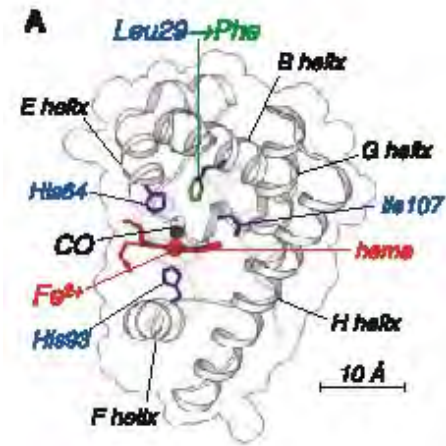

## Chemistry:

- Non-adiabatic molecular dynamics
- Quantum chemistry

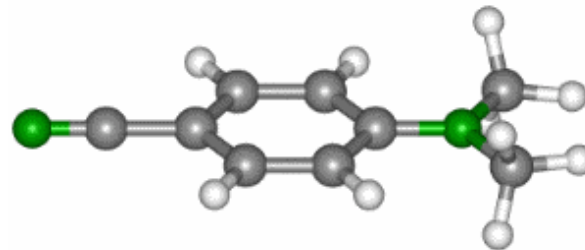

# Time Resolved X-ray Diffraction: Experiments

## Physics:

- Coherent phonons in Bi

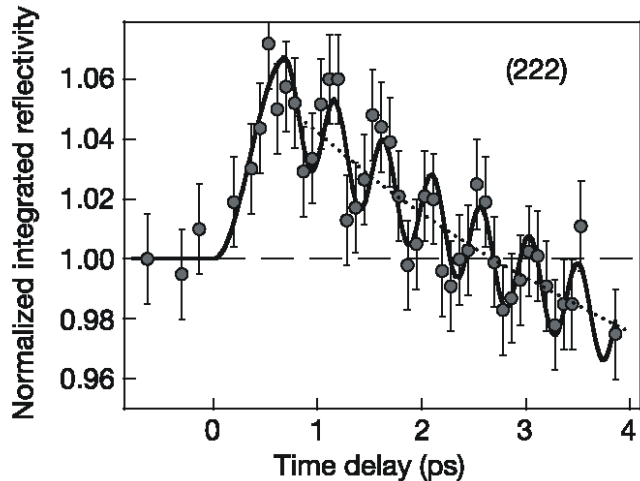

K. Sokolowski-Tinten et al.,  
Nature **422**, 287 (2003)

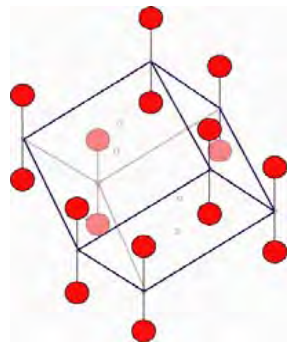

UXRD

## Chemistry:

- nonadiabatic molecular dynamics in solution

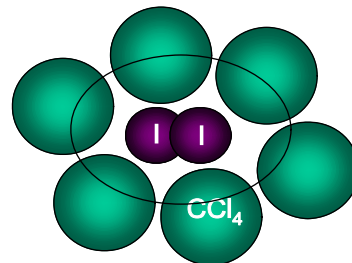

A. Plech et al. PRL **92**, 125505 (2004)

difference signal

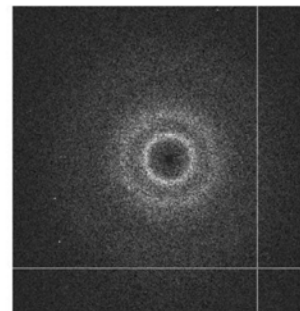

## Biology:

- Photodynamics of CO in Myoglobin

Bild: M. Wulff

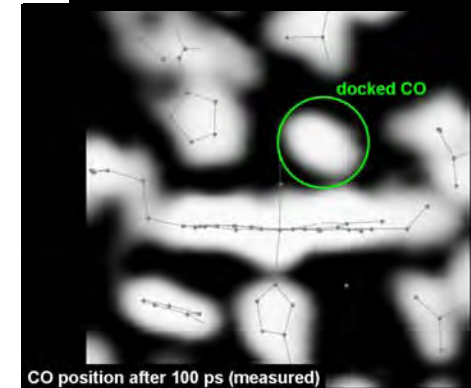

Schotte et al.,  
Science **300**, 1944 (2003)



# Multifunctional Oxide Materials

## Perovskite structure

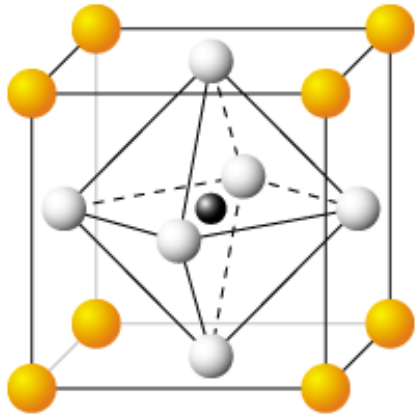

A-site cation (Ca, Sr, Ba, Pb, La, etc. 2+)



B-site cation (Ti, Ru, Mn, Zr, etc. 4+)



Oxygen (2-)

- Wide range of properties: dielectric, metallic, (anti)ferromagnetic, (anti)ferroelectric, superconducting, thermoelectric
- Present and future applications in data storage, spintronics, electro-optics, multiferroics, detectors, acoustics
- **1-ps-X-ray Bragg switch**

# Oxide Nanostructures

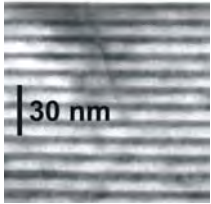

**MPI Halle:**  
D. Hesse,

**SRO:** SrRuO<sub>3</sub> (10 nm)  
metallic  
ferromagnetic below  $T_c \approx 160$  K

PZT (13.5 nm)  
piezoelectric  
ferroelectric

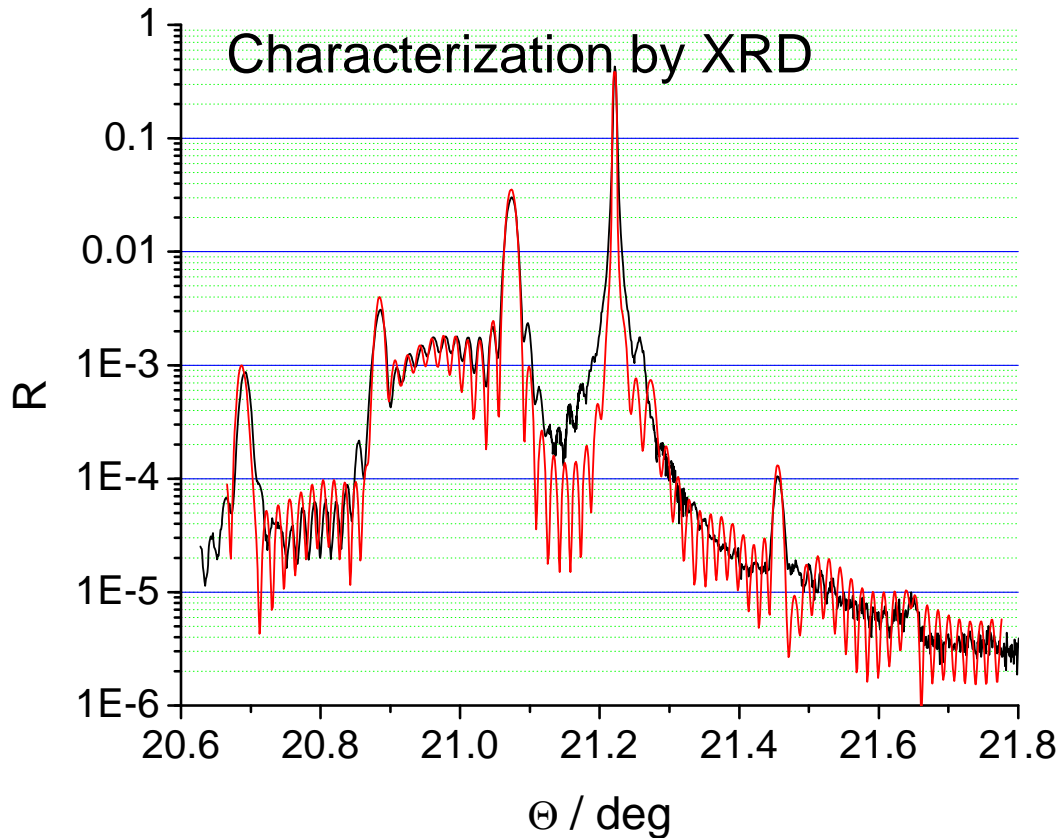

6nm 4nm 6nm 4nm

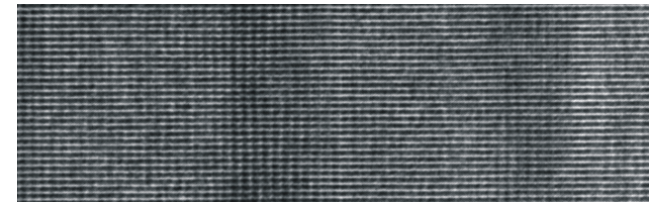

# Optical Excitation of Metallic/Ferroelectric Nano-Layers

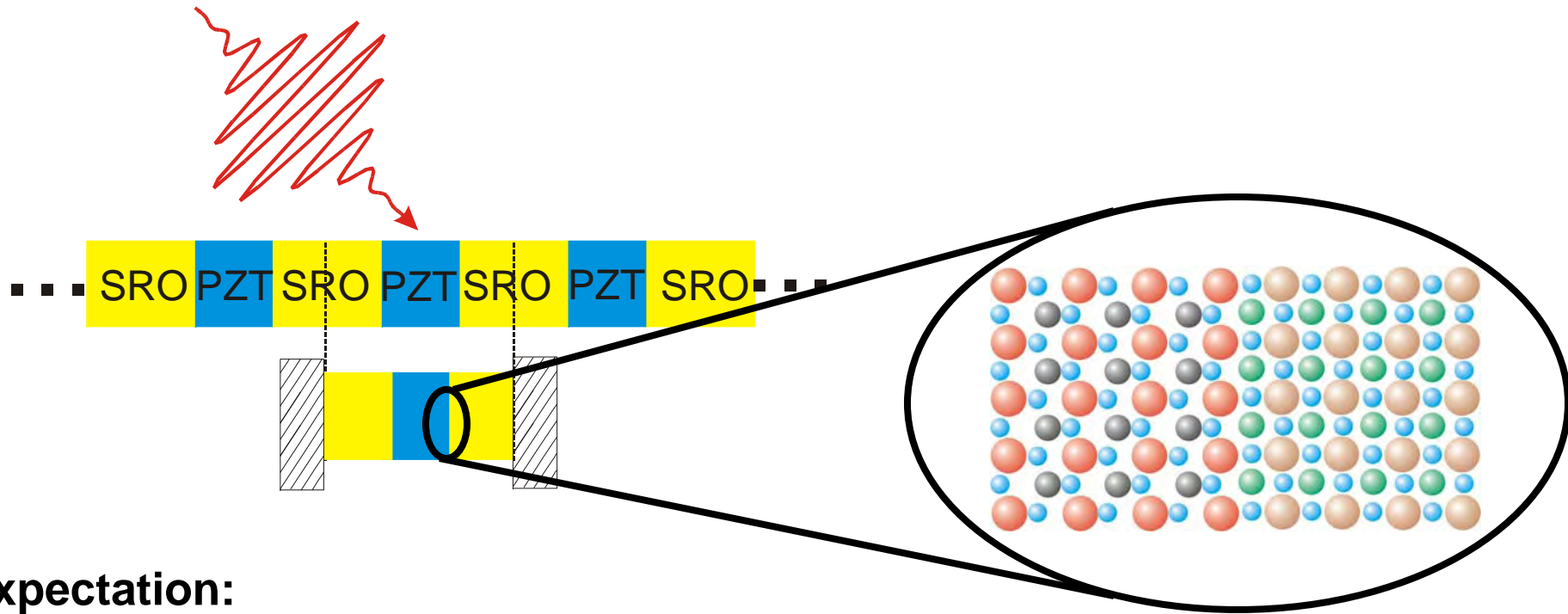

## Expectation:

- Excitation of electrons in metal (SRO)
- Expansion of SRO → compression of PZT → standing Wave
- Layer-thickness / sound-velocity  $\sim 2$  ps

## Questions:

- How does electron-excitation induce nuclear motion? (e – ph coupling)
- Are specific modes coupled?
- Magnetisation? Polarization?

# All-optical data: Transient reflectivity

SRO / STO multilayer,

pump 800 nm, 40.2 mJ/cm<sup>2</sup>  
probe white light

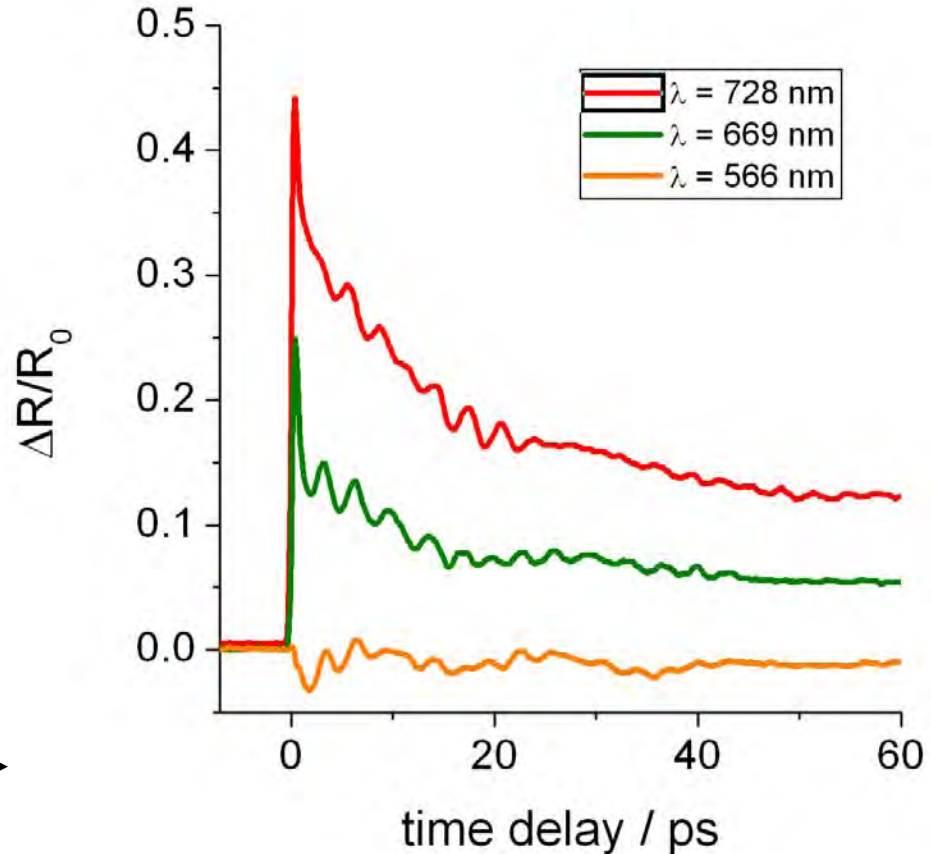
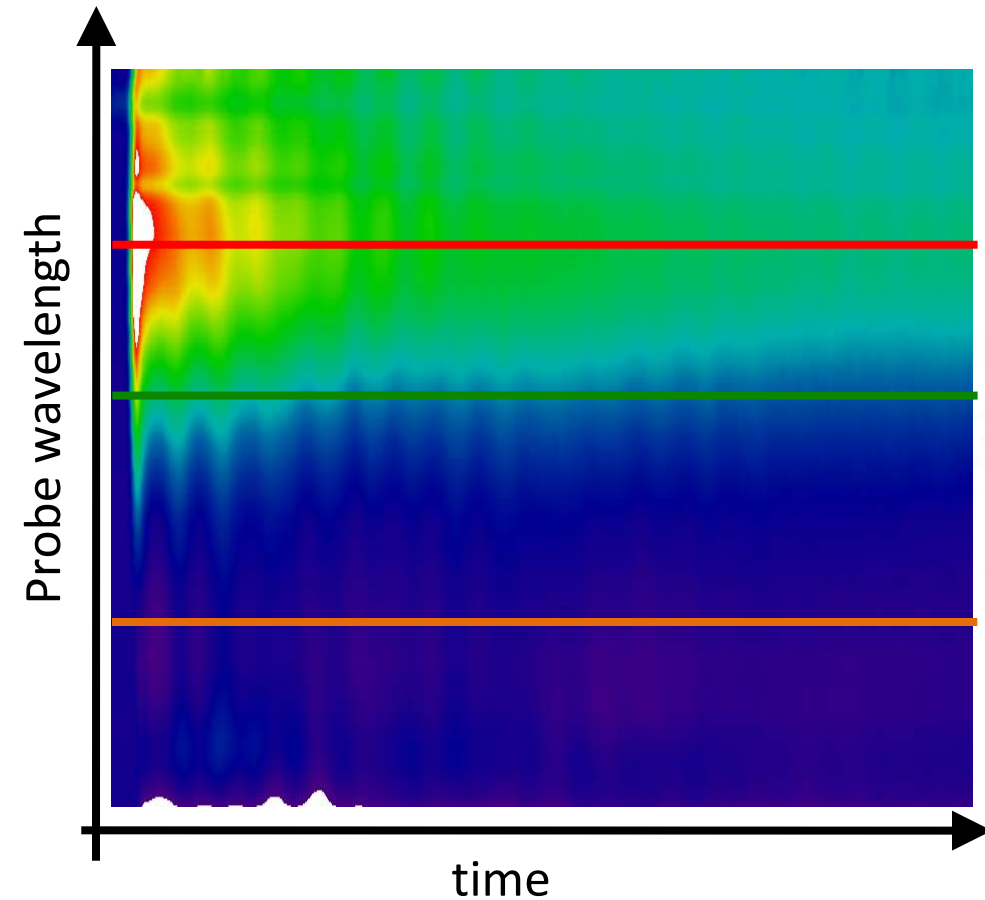

# Phonon Simulations

## 1. Electronic excitation (intraband)

Phonon modes and photoelastic effect ( $dn/d\varepsilon$ )

interference of light reflected off surface and traveling strain pulse

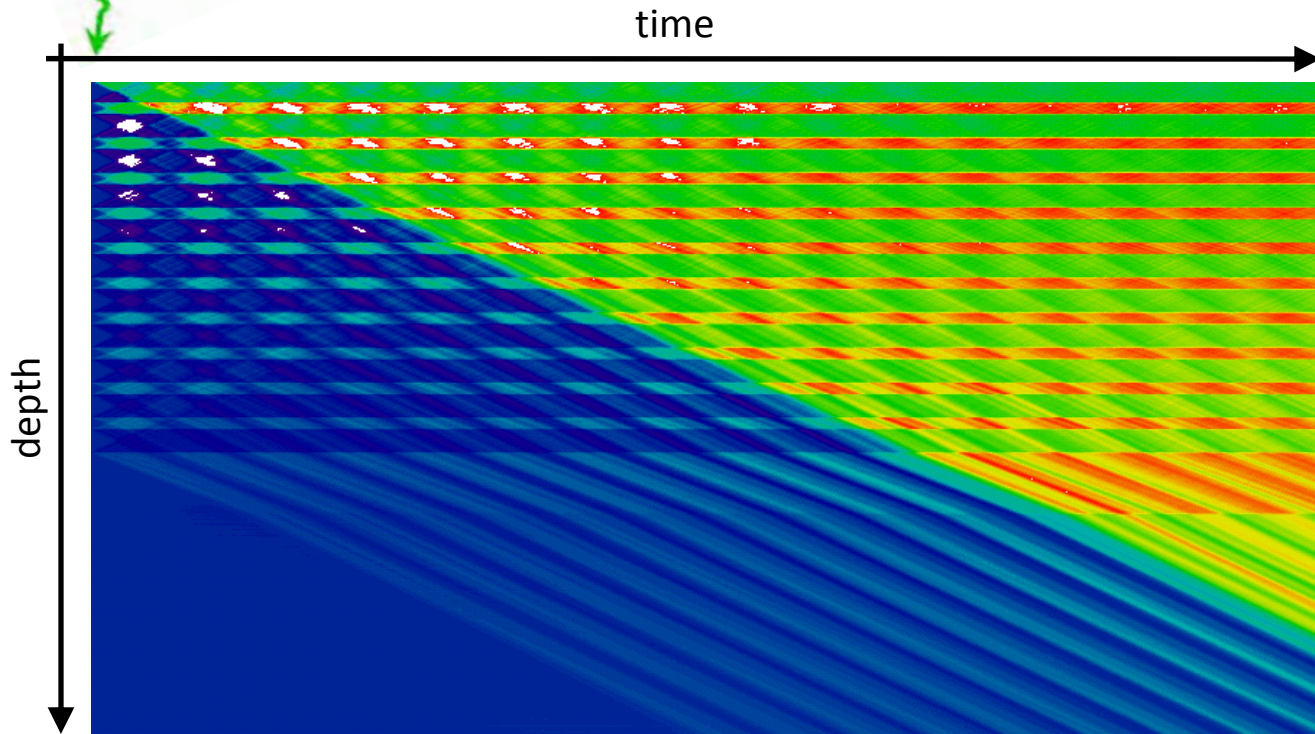

Spatio-temporal strain distribution

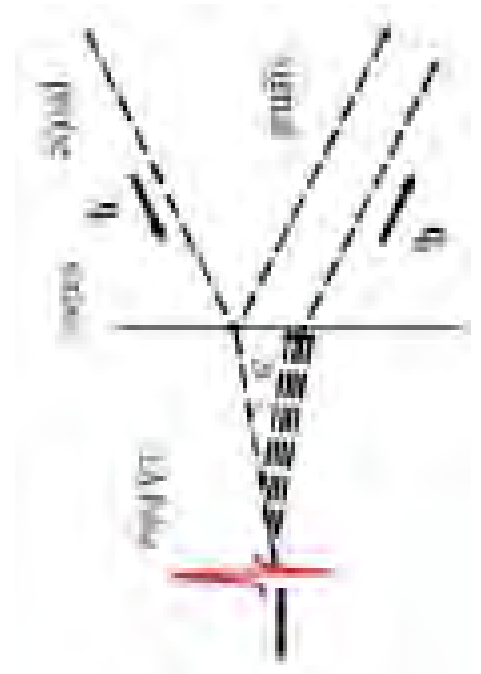

# Ultrafast X-ray Diffractometer

## X-ray diffraction

- Direct determination of structures
- Resolution 100 fm

## Stroboscope (Pump-Probe):

- Transition states, non-equilibrium
- Resolution 100 fs
- $\sim 10^6$  photons /s on sample

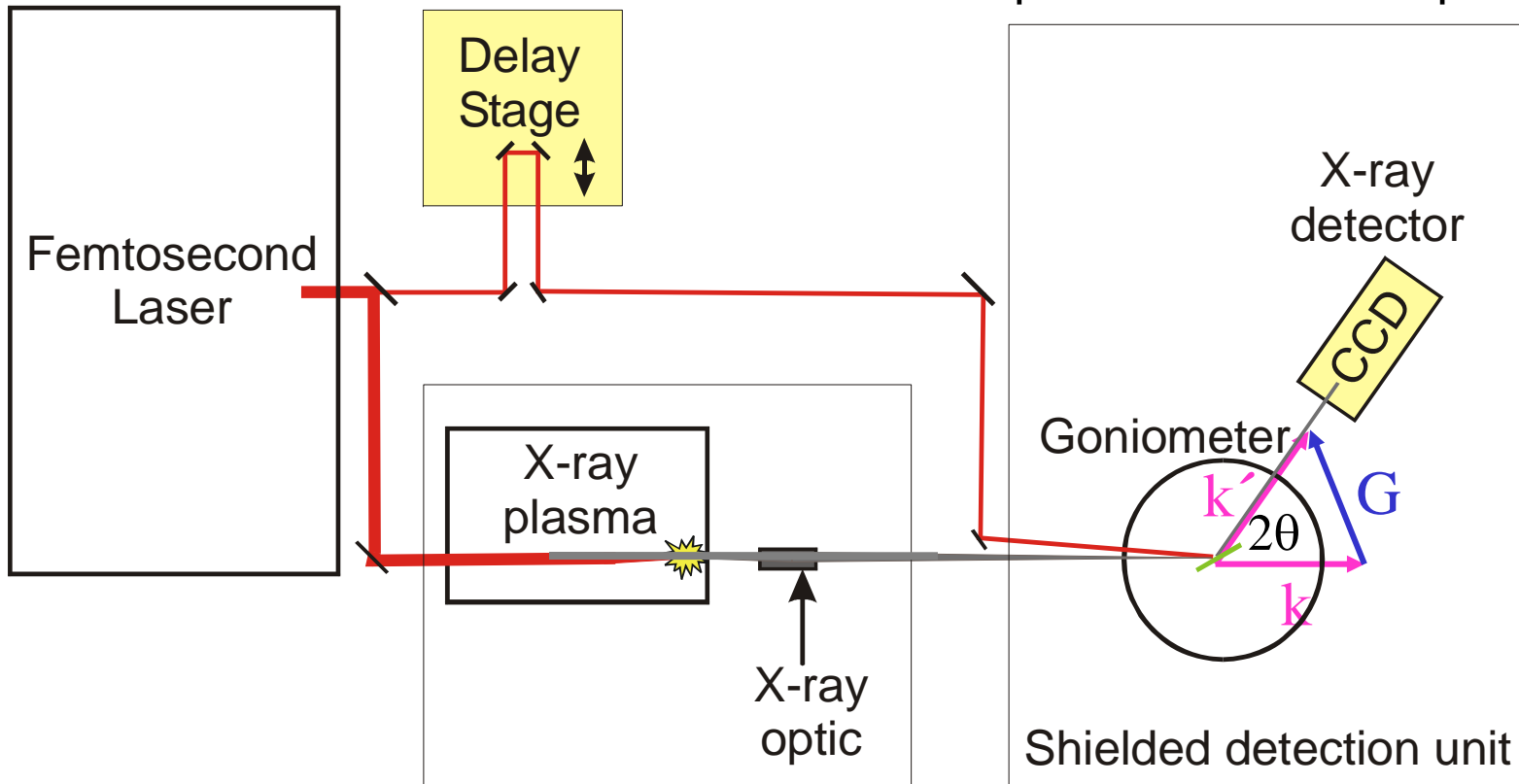

# Ultrafast X-ray Diffraction: Setup

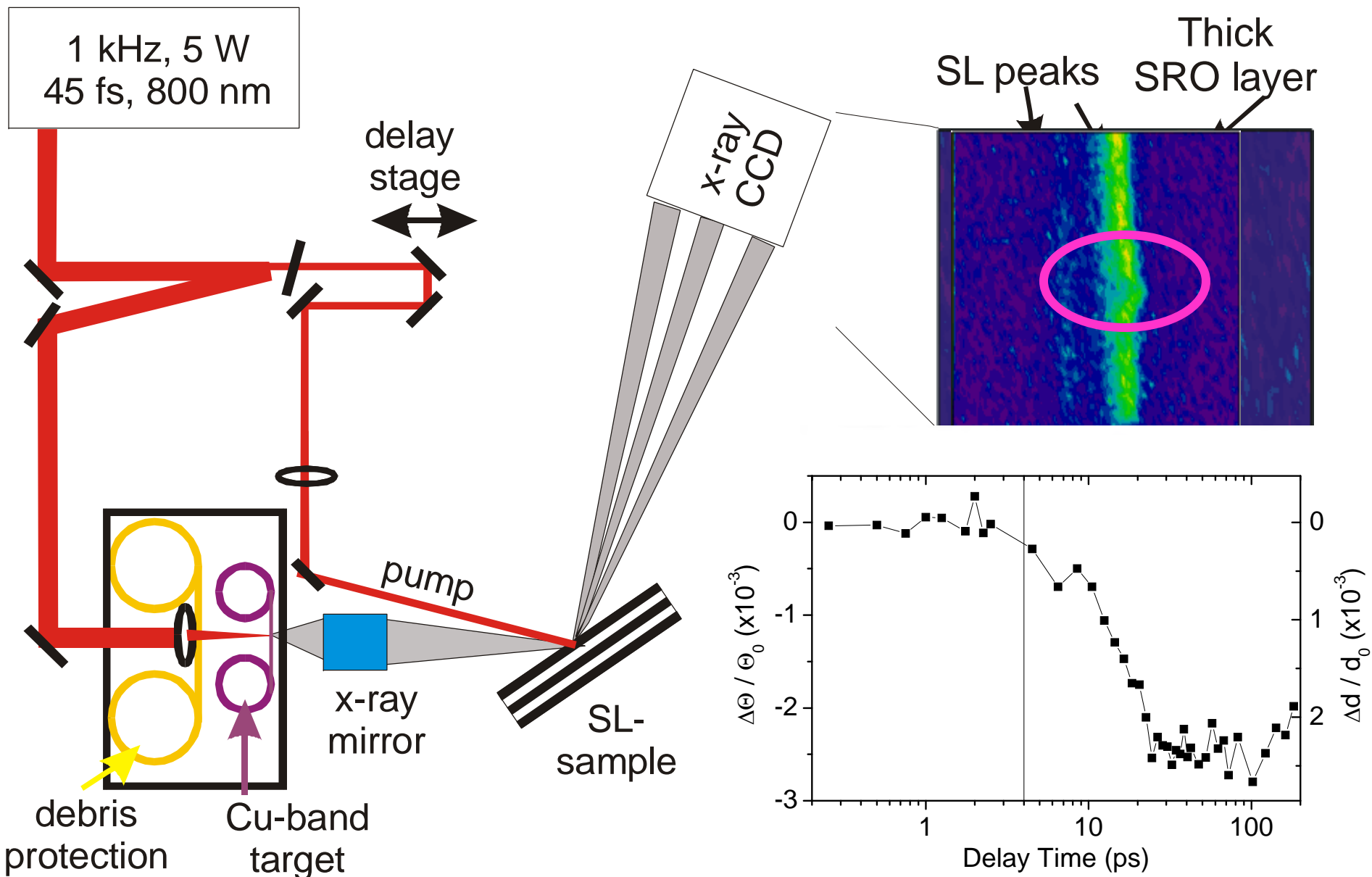

# Classification of observed changes:

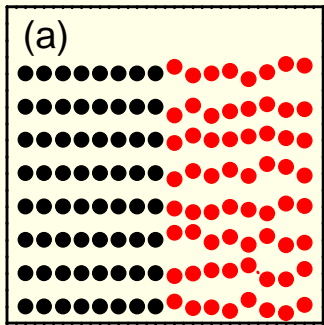
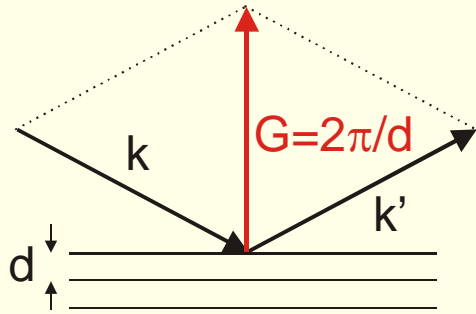

disorder

intensity reduction

$$\exp(-\langle u_G^2 \rangle G^2)$$

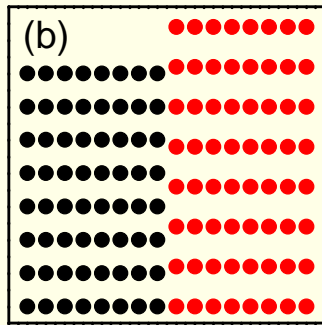

hom. acoustic deformation

tensile/compressive

line shift

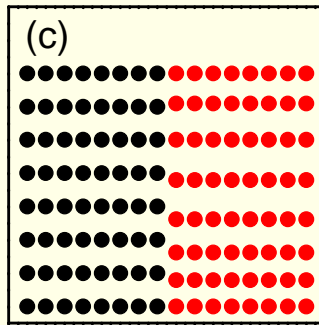

LA phonon

$$G_{\text{lattice}} \pm Q_{\text{phonon}}$$

sidebands

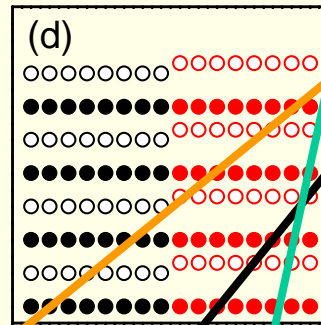

hom. optical deformation

pos. / neg. intensity modulation  $\propto u$

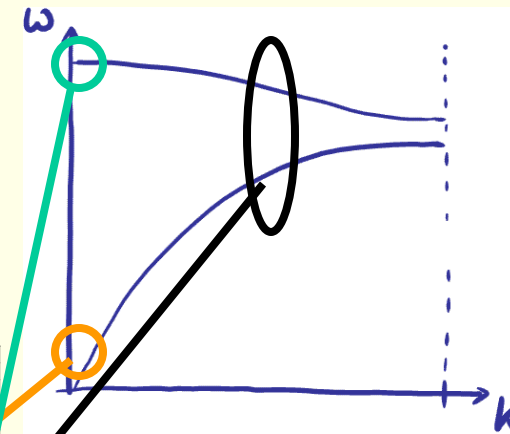
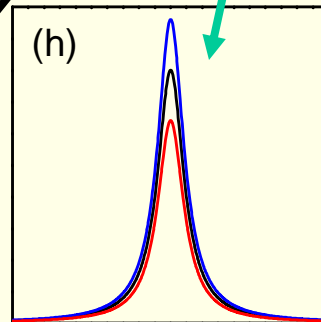
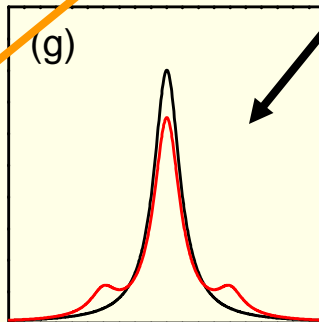
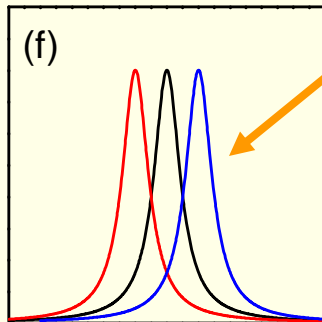
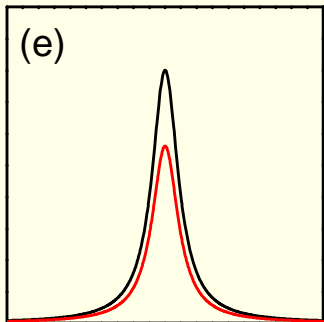

# Ultrafast X-ray Diffractometer

## X-ray diffraction

- Direct determination of structures
- Resolution 100 fm

## Stroboscope (Pump-Probe):

- Transition states, non-equilibrium
- Resolution 100 ps / slicing 100 fs

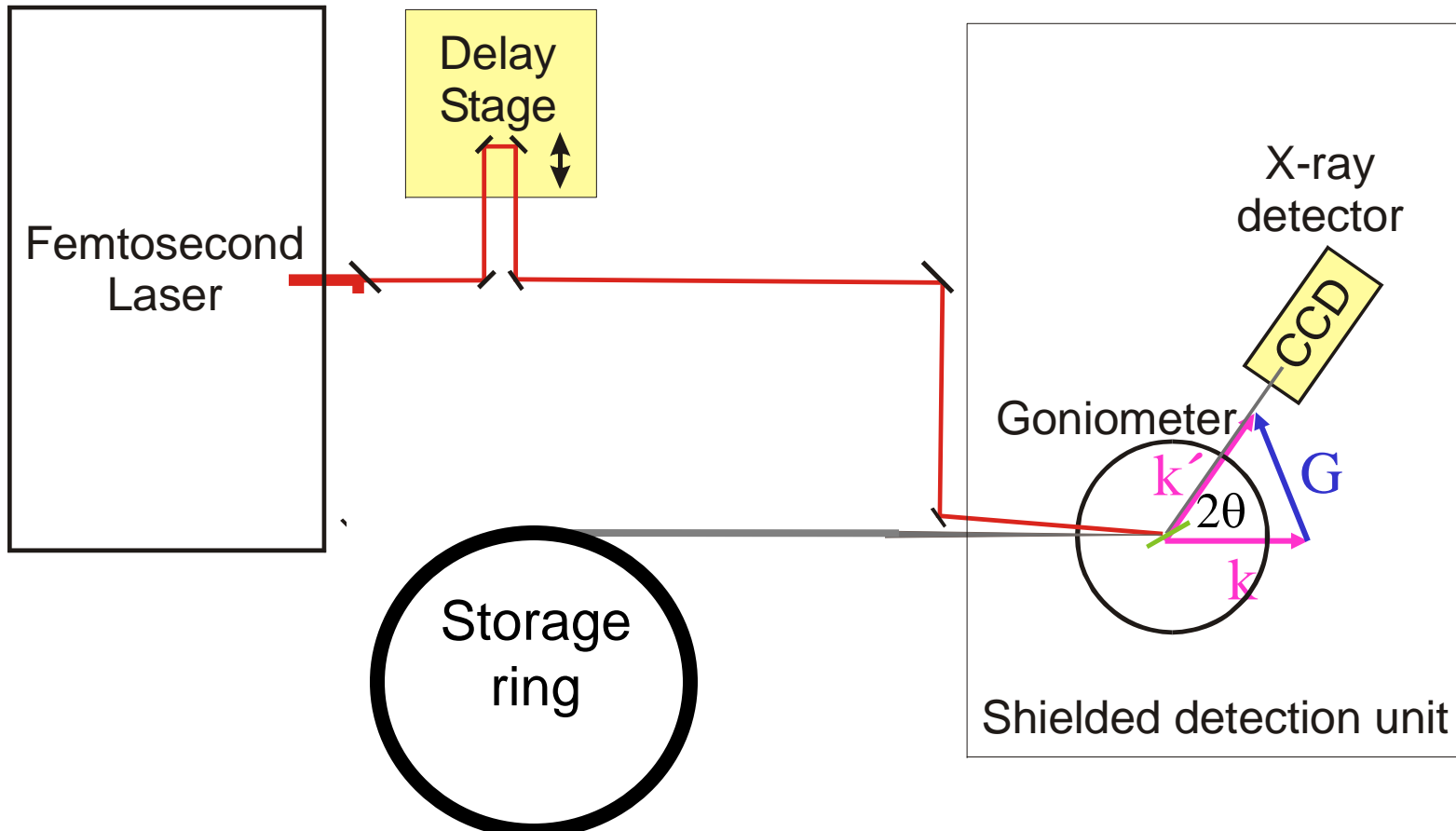

# Comparison Plasma Source vs. Slicing Beamline at the Swiss Light Source

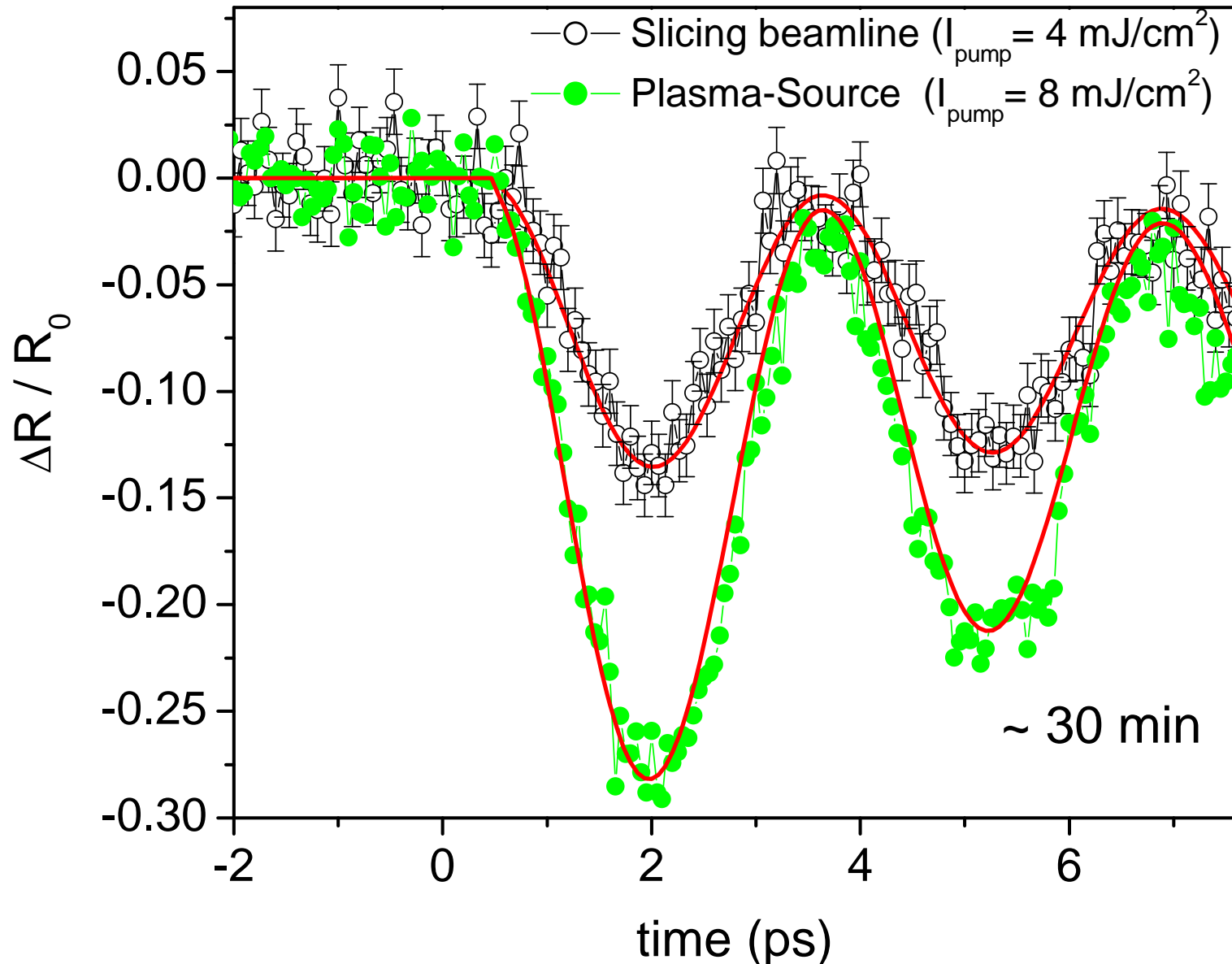

# Understanding XRD from Multilayers

Convolution Theorem:  $FT(f * g) = FT(f) \cdot FT(g)$

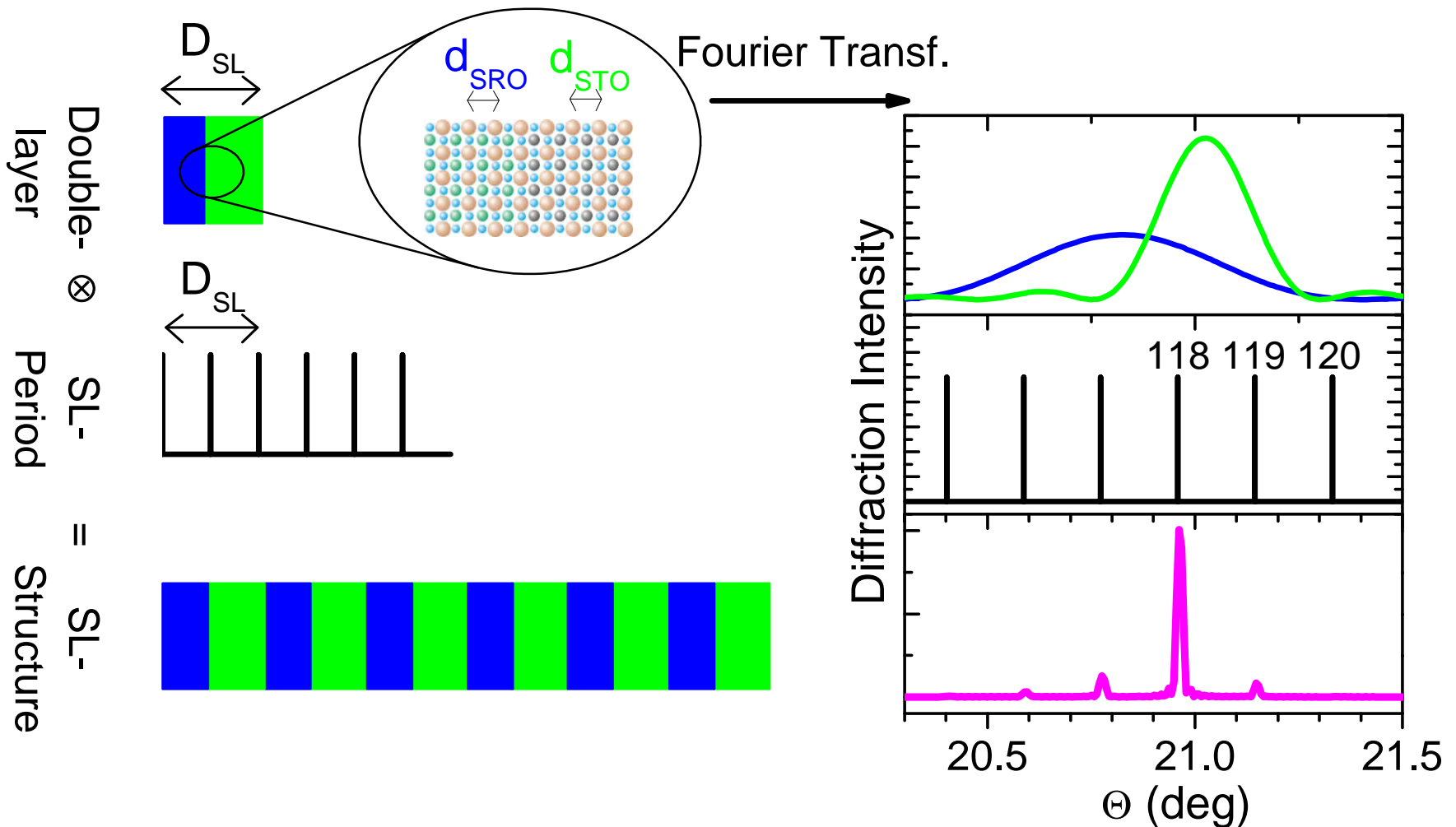

# Understanding XRD from Multilayers

Convolution Theorem:  $FT(f * g) = FT(f) \cdot FT(g)$

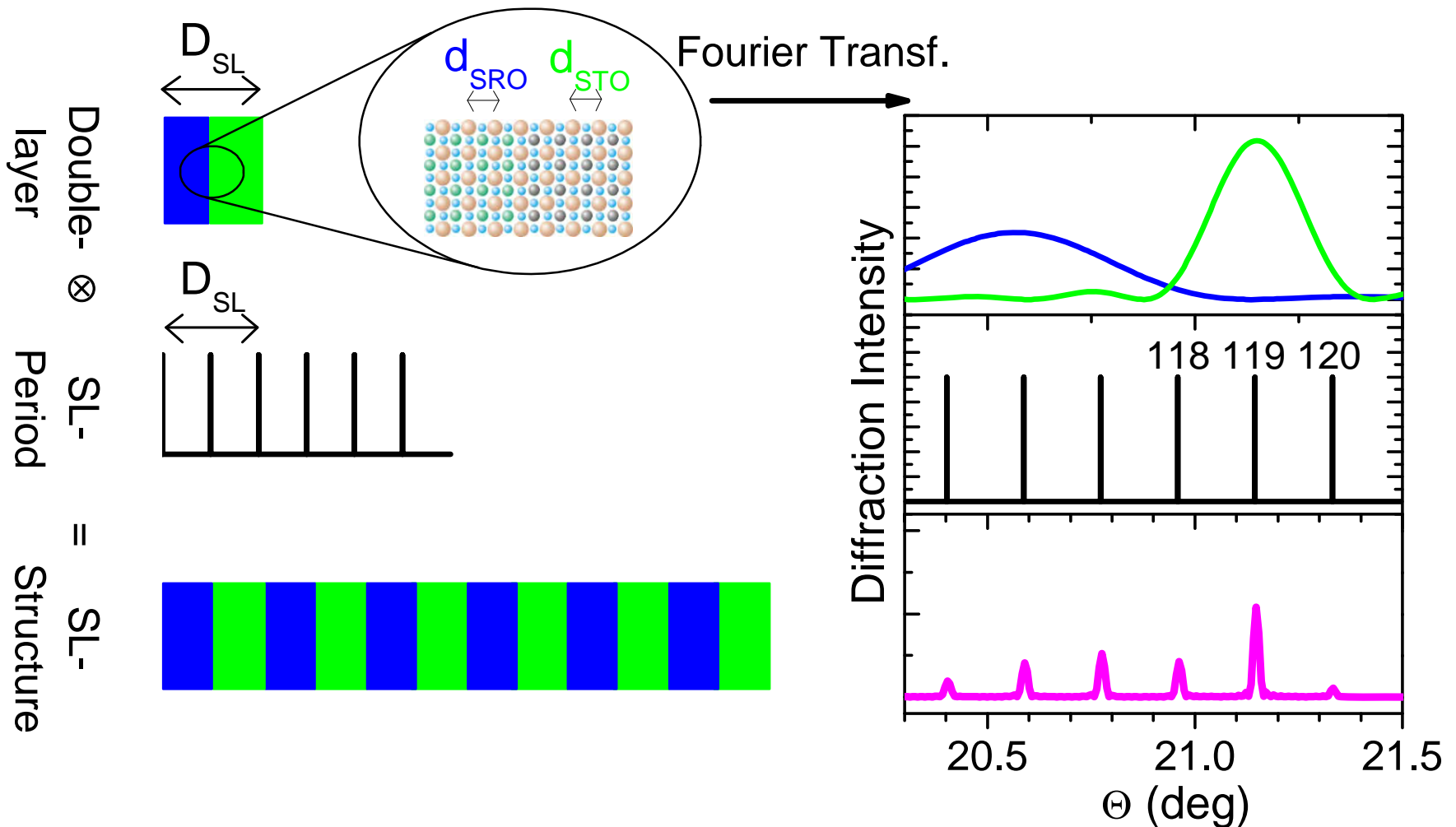

# Rocking Curve of Multilayer

SRO / STO multilayer

; X-ray energy: 5.2 keV

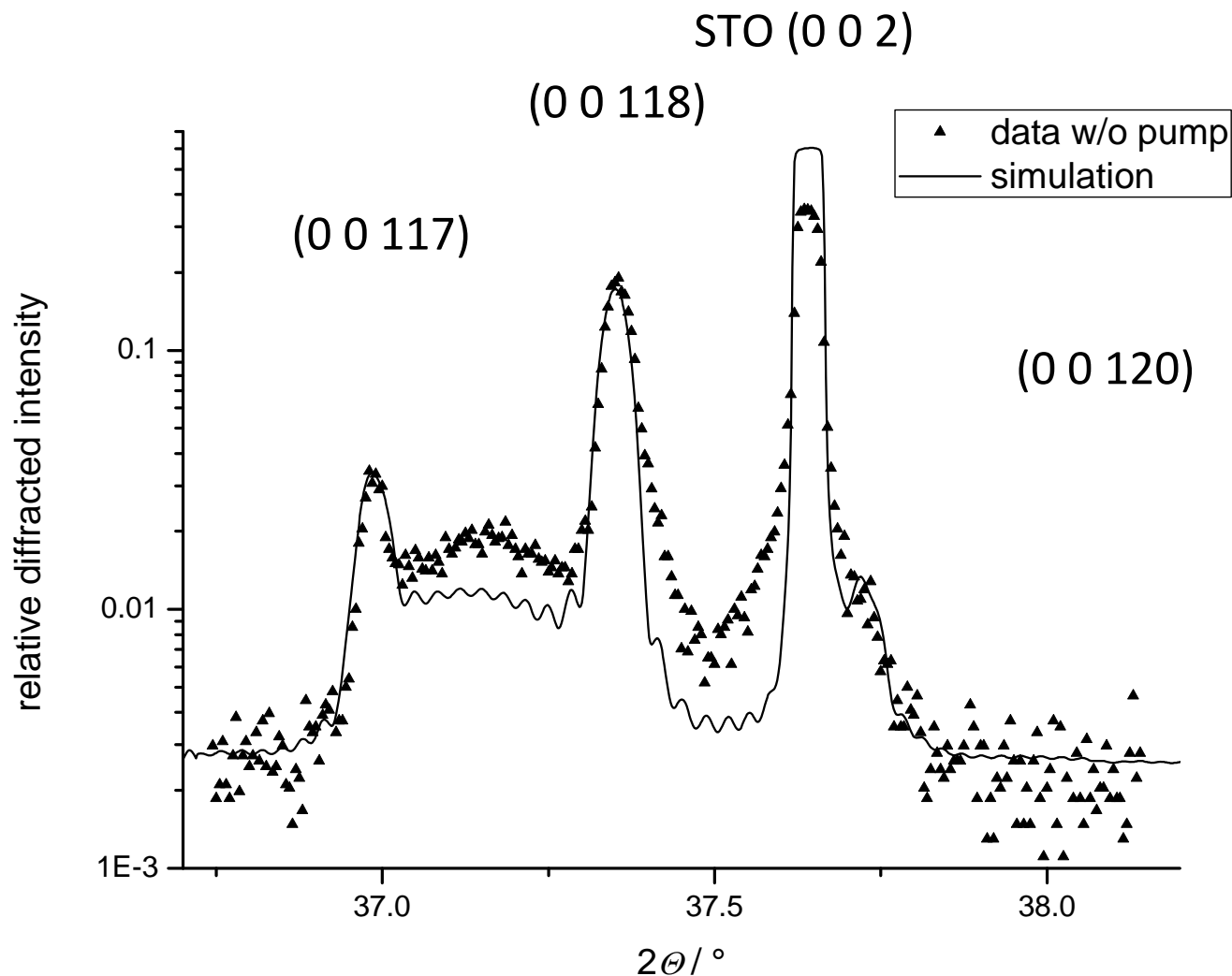

SRO / STO lattice constants

Layer thicknesses

Strain level compared to bulk

# Rocking Curve of Excited Multilayer

SRO / STO multilayer at  $\tau = 1.6$  ps, 30.8 mJ/cm<sup>2</sup>

; X-ray energy: 5.2 keV

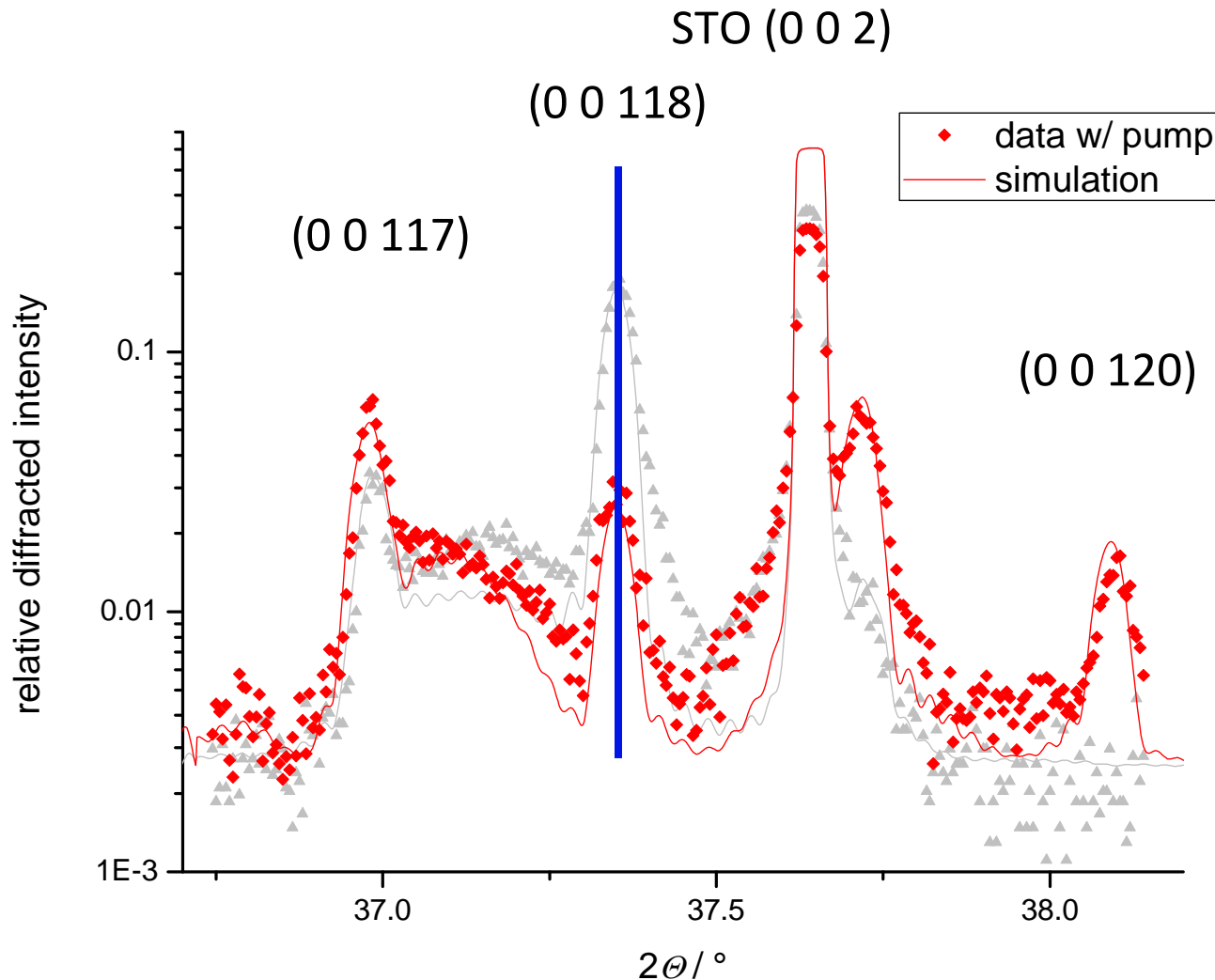

SRO strain  $\approx$  1.2 %

$$\Delta I/I^{118} = -86\%$$

Drastic changes in  
only **1.6 ps!!**

# Suppression of Peaks

Strong intensity modulation of reflection 118

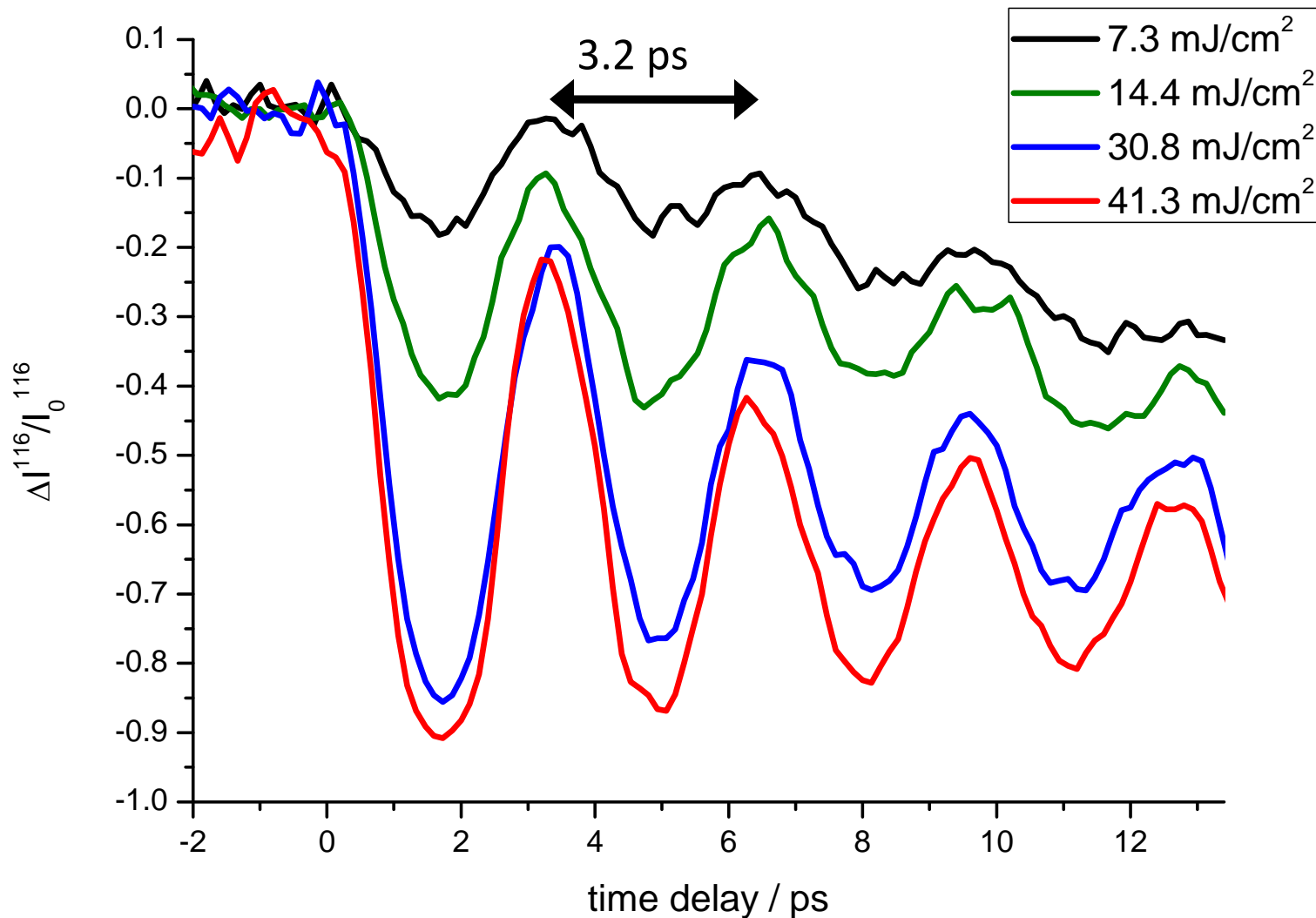

Phonon period of  
3.2 ps

Intensity drop up  
to **91% !!**

Strain generation  
up to **1.4% !!**

# Rocking Curve of Excited Multilayer

SRO / STO multilayer at  $\tau = 1.6$  ps, 30.8 mJ/cm<sup>2</sup>

STO (0 0 2)

(0 0 118)

(0 0 117)

(0 0 120)

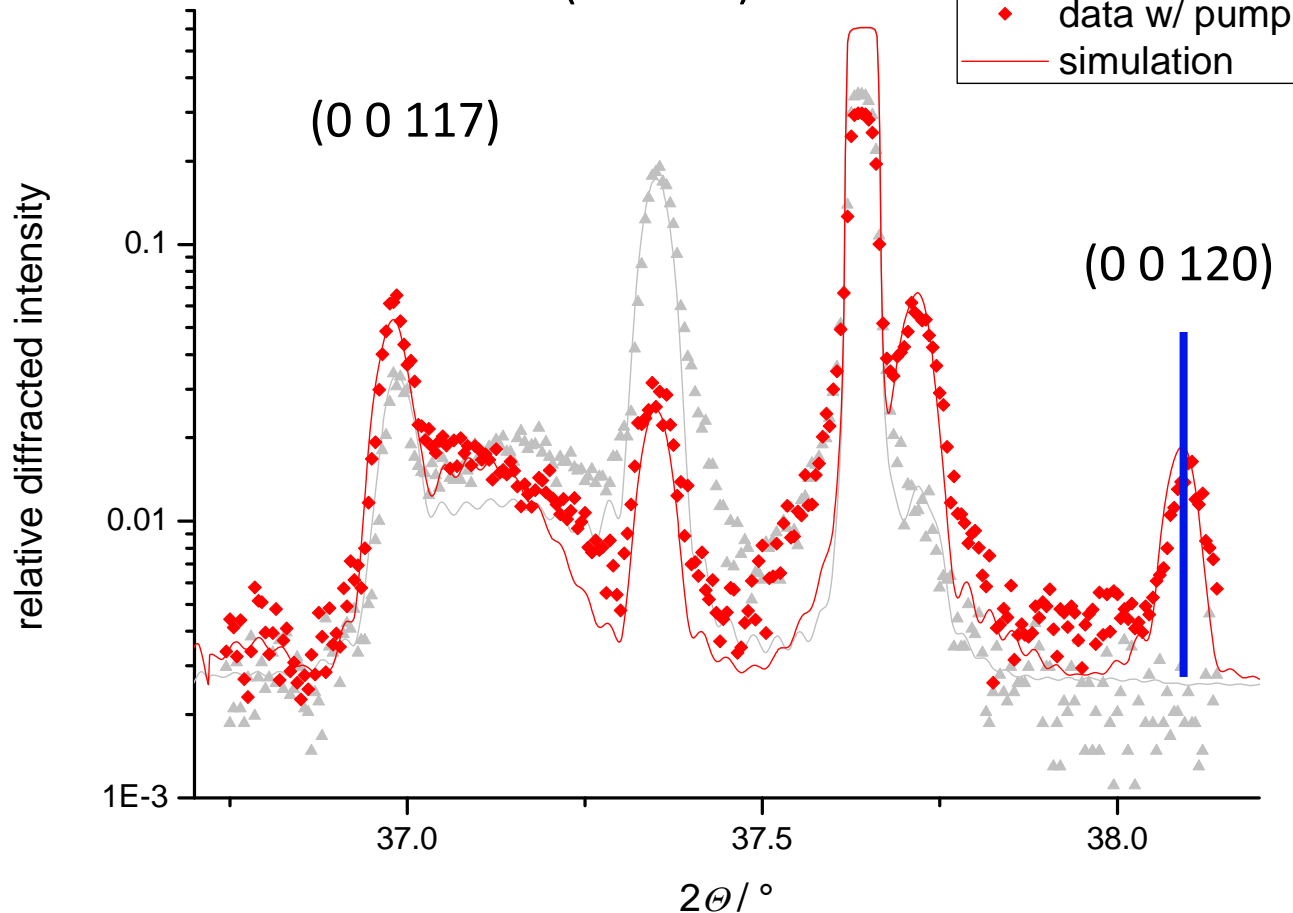

SRO strain  $\approx 1.2$  %

$\Delta I / I^{120} = +1350\%$

Drastic changes in  
only **1.6 ps!!**

# Switching "on" the Structure Factor

- Nonlinear response to strain
- Spikes rather than oscillations
- Temporal width of 1 ps !!

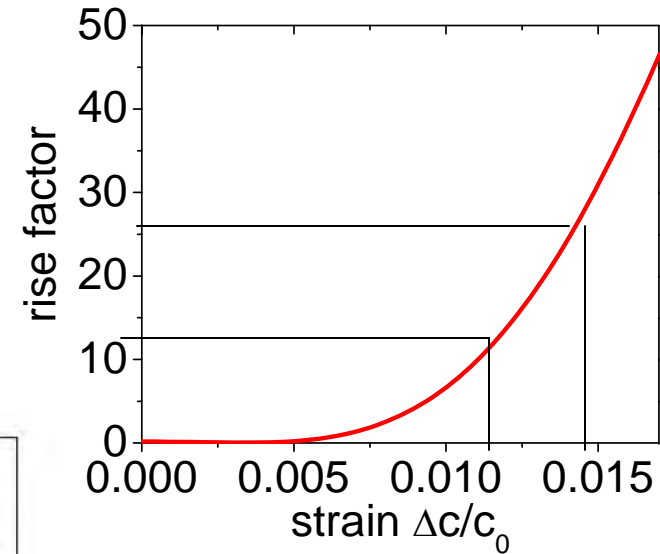
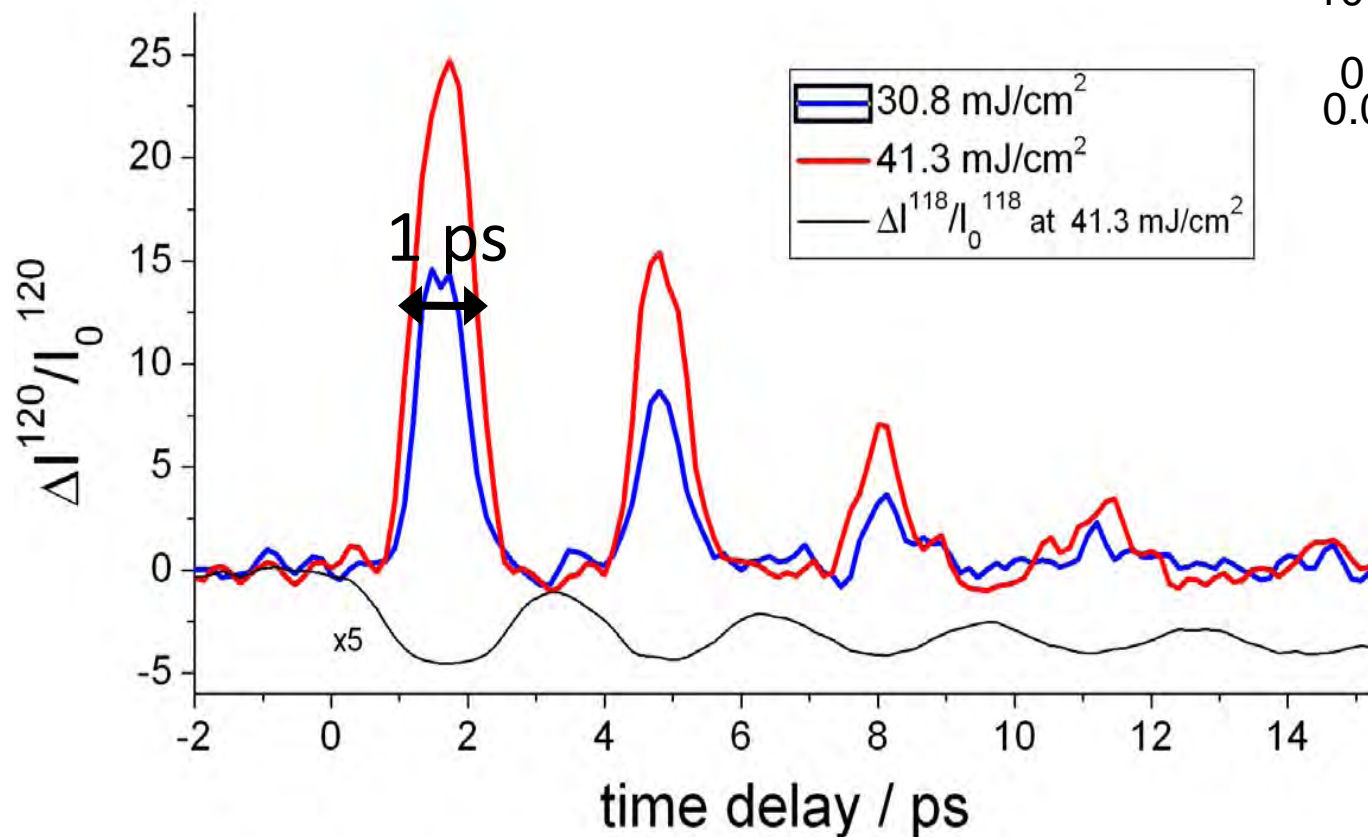

# Shift and Broadening of Rocking Curves

Time scale of shift given by  $T_{shift} = \frac{D_{tot}}{\bar{v}_{LA}} \approx 37 \text{ ps}$

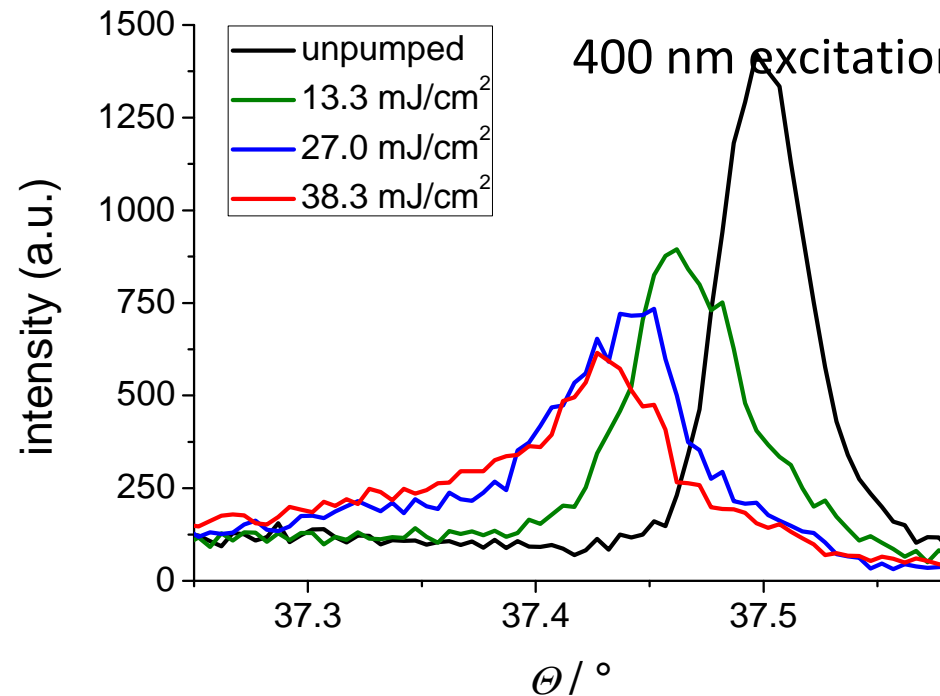
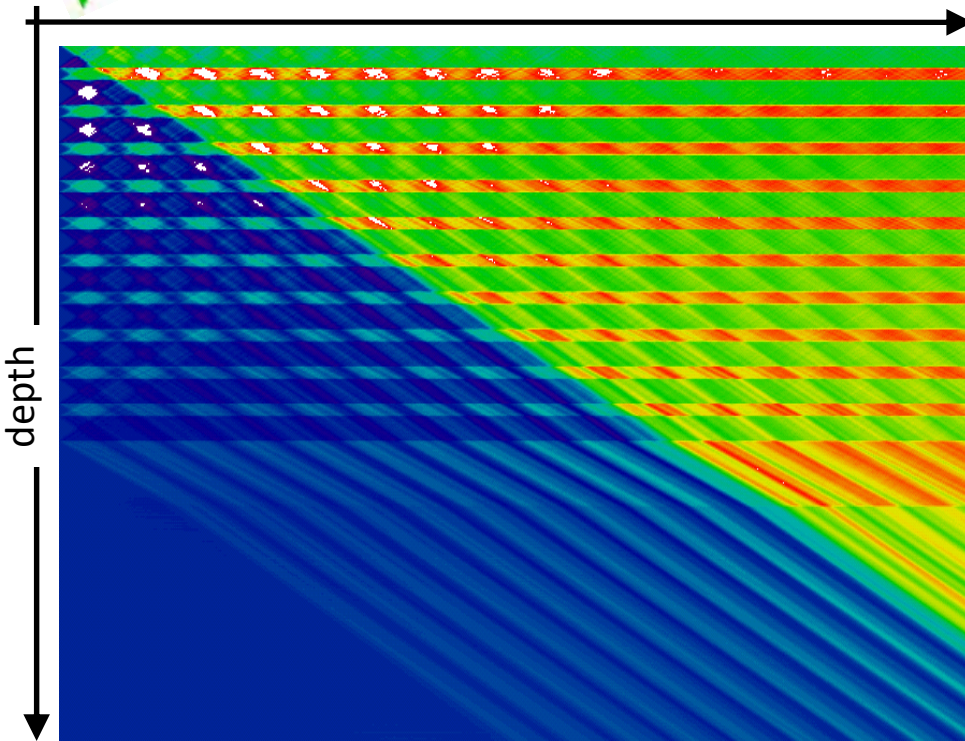

- Magnitude of shift  $\sim$  time and fluence
- Large shifts + broadening of peaks
- 400 nm: asymmetric rocking curves  $\rightarrow$  inhomogeneous excitation

## Conclusion:

- Intensity  $\rightarrow$  structure factor  $\rightarrow$  (optical) phonon amplitude (1.4 %)
- Shift of peaks  $\rightarrow$  expansion of structure  $\sim$  pump **fluence** and **time**
- Assymetry of shift  $\rightarrow$  inhomogeneous expansion
- Very large structure change directly evidenced by rocking curve
- Application: Manipulate X-rays on sub-ps time scale  
 $\rightarrow$  **Ultrafast X-ray Switch** ( $< 1$  ps, predicted modulation 20000%)

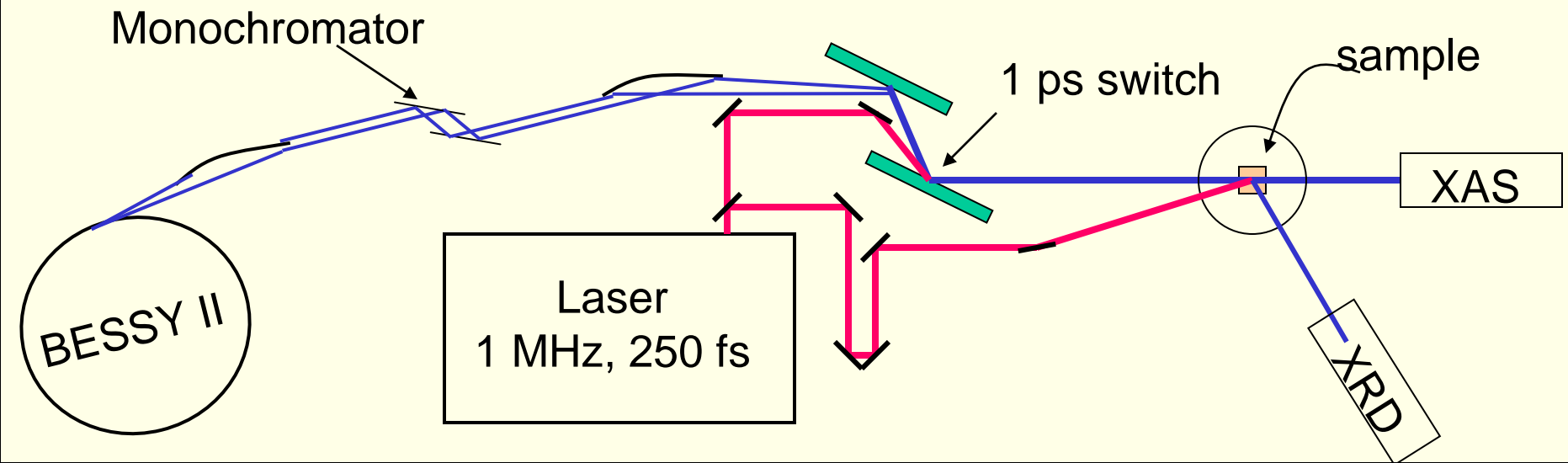

# Origin of Nuclear Motion

Each phonon mode is equivalent to a harmonic oscillator

Electron-phonon-interaction

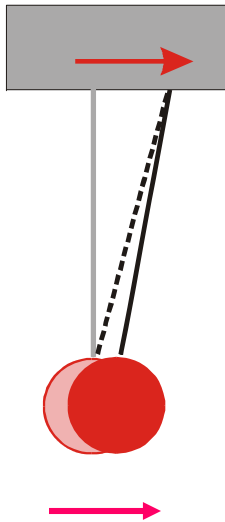

Phonon-phonon-interaction

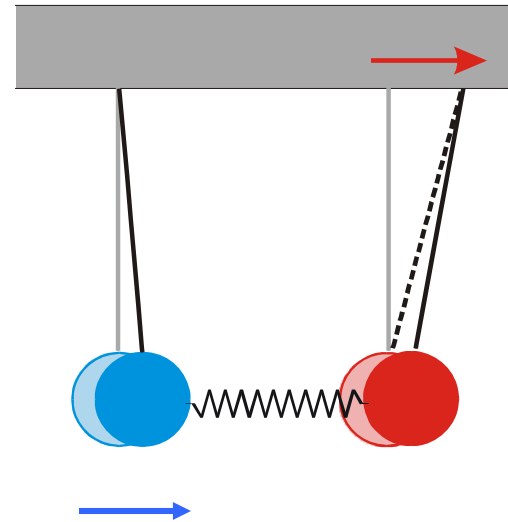

# Mechanism for expansion of SRO

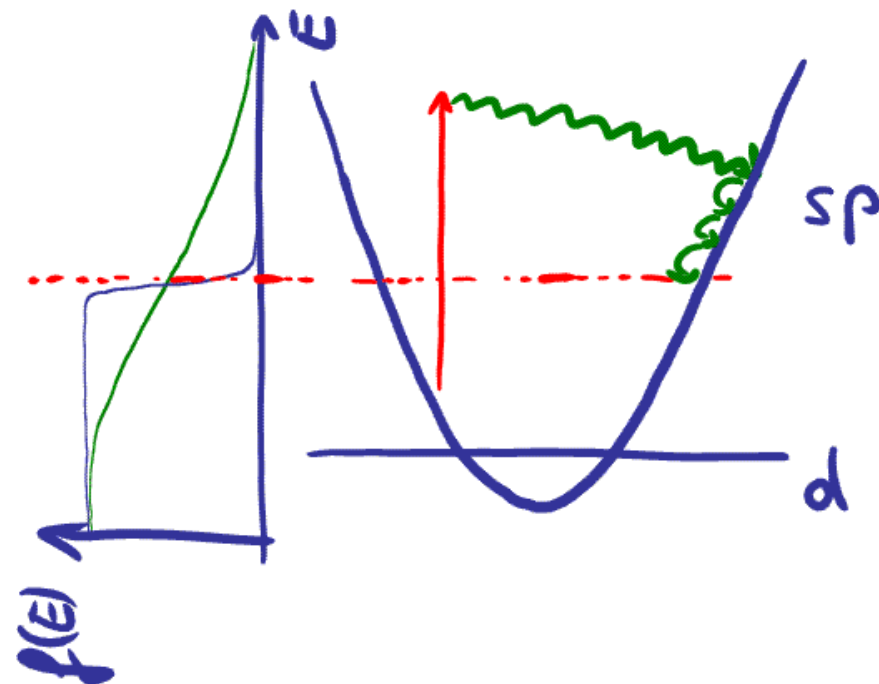

$$\frac{d\eta^2}{d^2t} + \omega_0^2 \eta = F(t)$$

- Rise time of pressure  $\tau_{\text{rise}} = 500$  fs

⇒ Pressure by „hot phonons“

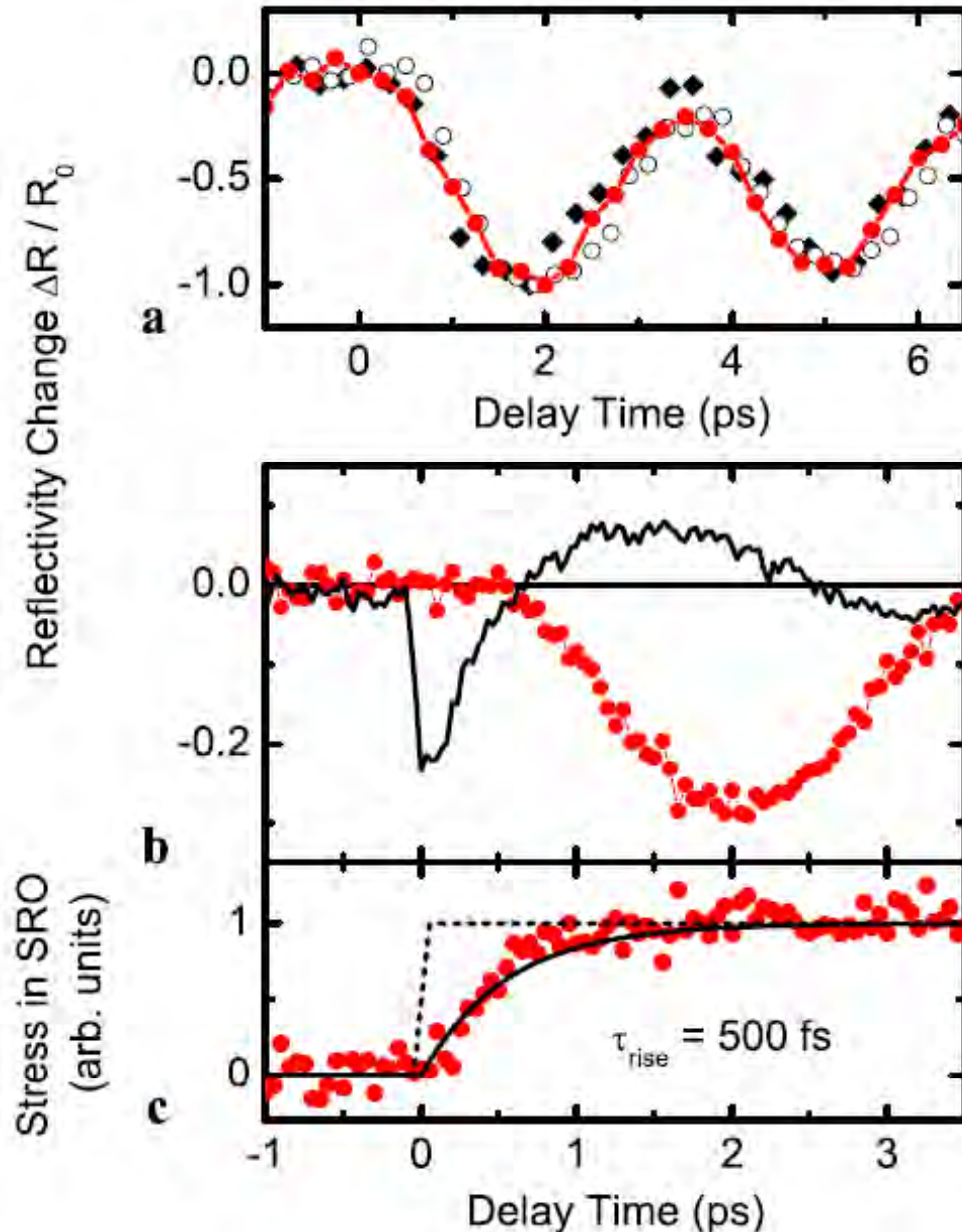

# Ultrafast Demagnetisation

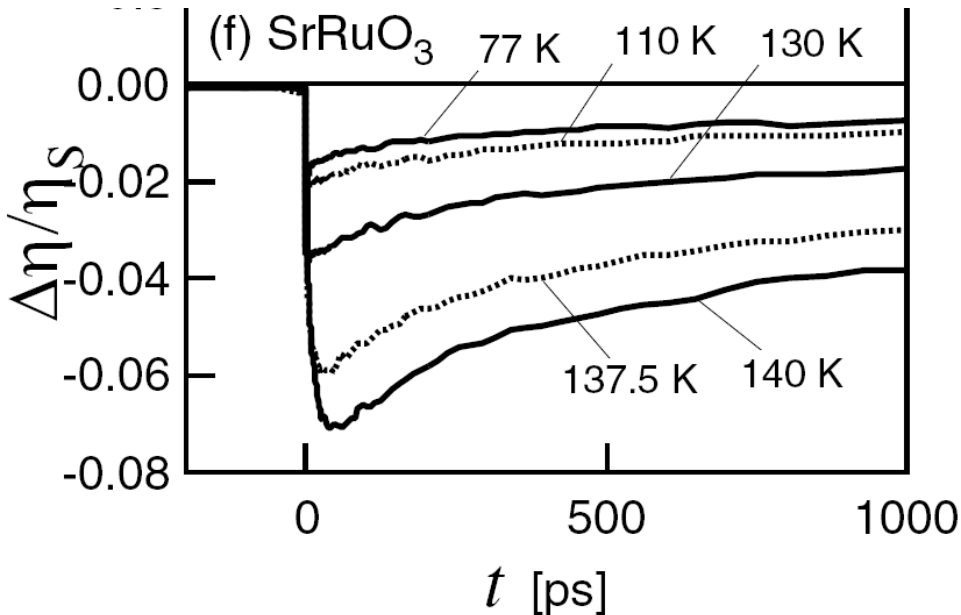

## Density of states:

- Stoner-excitation at 4000 cm<sup>-1</sup> ?

## Faraday Rotation: Ogasawara

- Magnetisation reduced by optical excitation at 800 nm
- Fast component due to electron-magnon-coupling in SRO ( $t < 0.2$  ps)

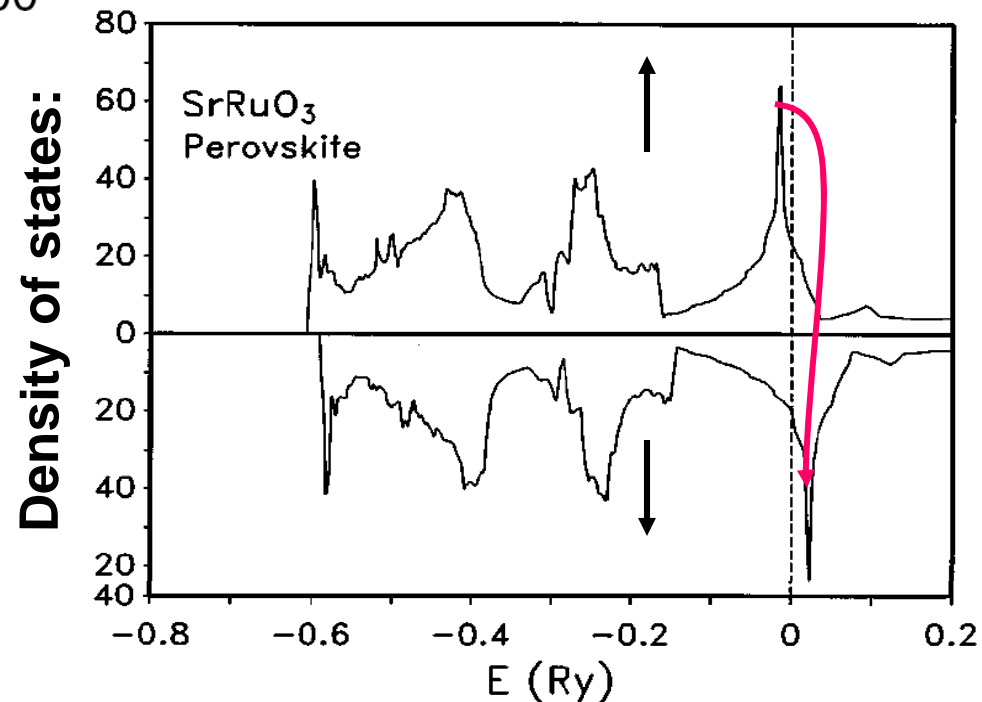

# Negative Pressure by Magnetostriction

## STO / SRO:

SRO ferromagnetic below  $T_C < 160$  K

- Below  $T_C$ : reduced phonon amplitude

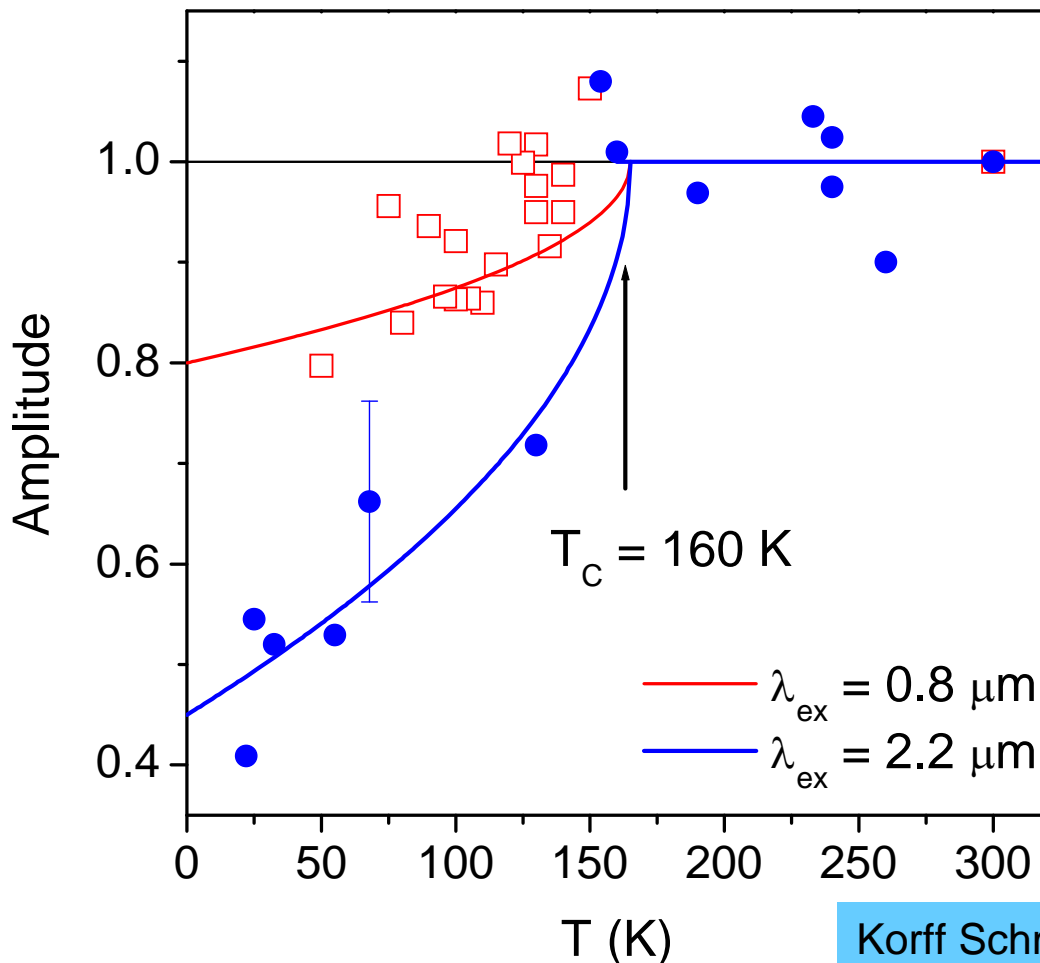

- Negative pressure in SRO by destroying magnetization (magnon excitation)
- This magnetostrictive force is nearly instantaneous!

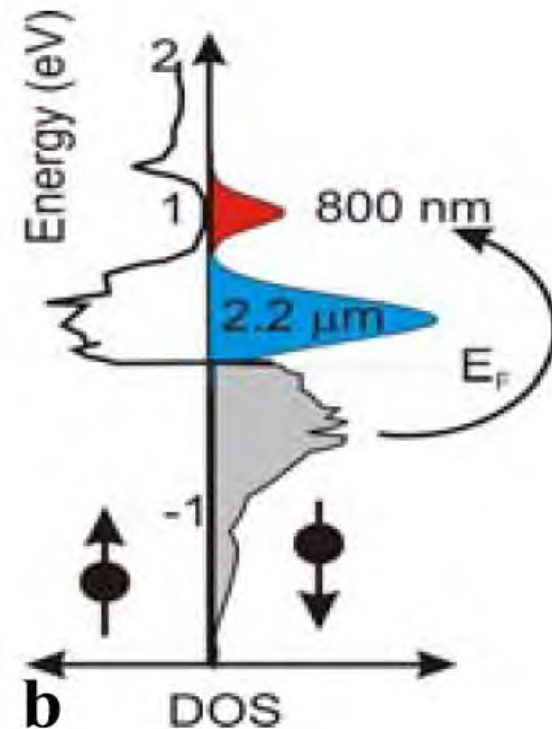

# Supporting Data: Invar-Effect

## Invar-Effect:

- Neutron scattering
- Higher temperature (energy) does not expand the lattice at  $T < 160$  K
- Above  $T > 160$  K expansion as expected
- Rotation of oxygen octaeder stabilises ferromagnetic ordering

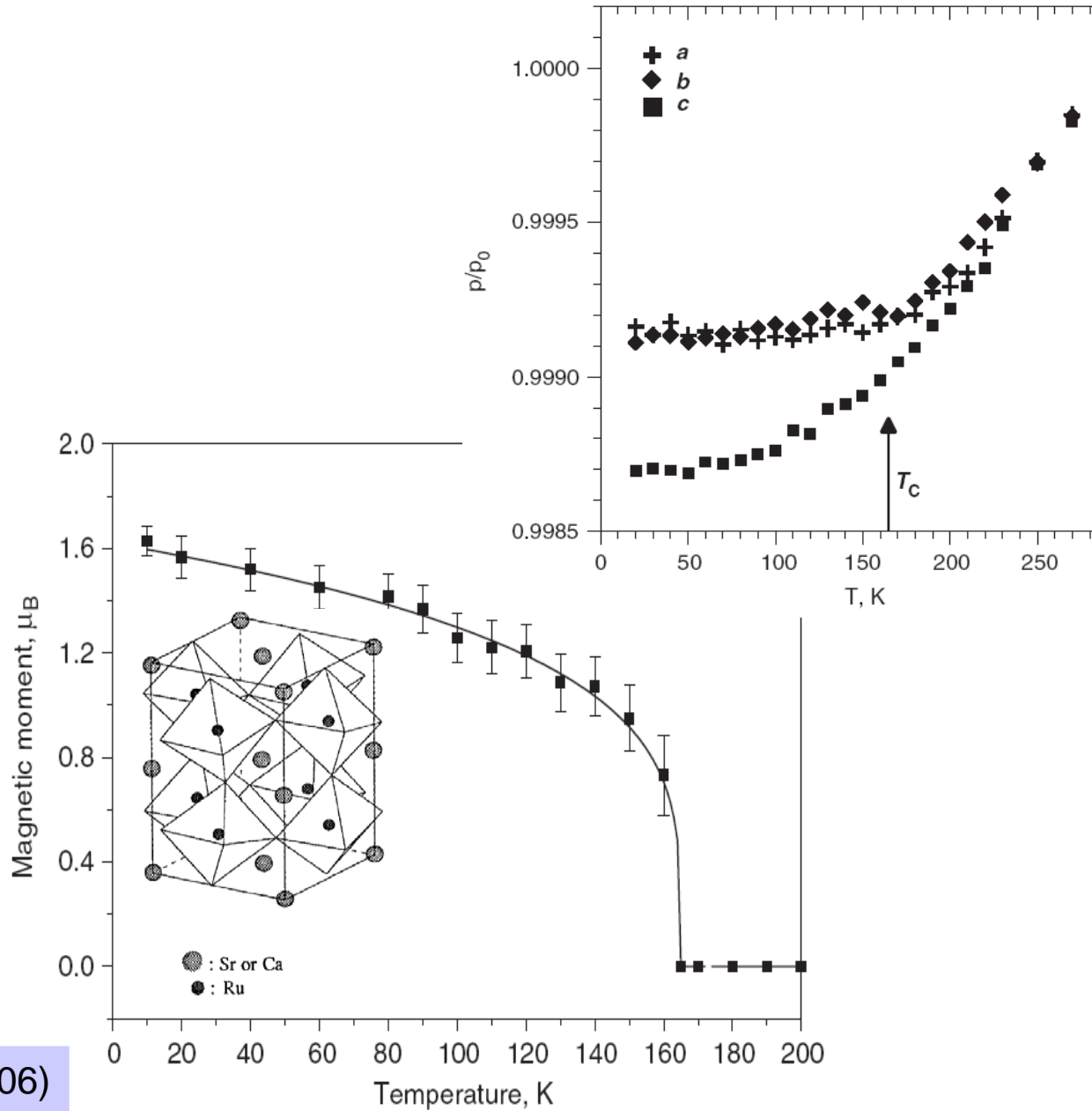

# Open Questions

- Does electronic excitation couple to specific modes (except expansion)
- What is the role of specific orbitals and hybridization?
- What is the role of localization, symmetry breaking, domain formation
- What are the relevant coordinates? Oxygen octahedra-tilts?
- Symmetry conserving? Volume-conserving?

## What determines the ultrafast function (structural change)?

- Direct excitation of coherent motion
- Suppression of barrier defined by several coordinates
- More complex (and realistic schemes) Entropy? Domains?

**Reality**

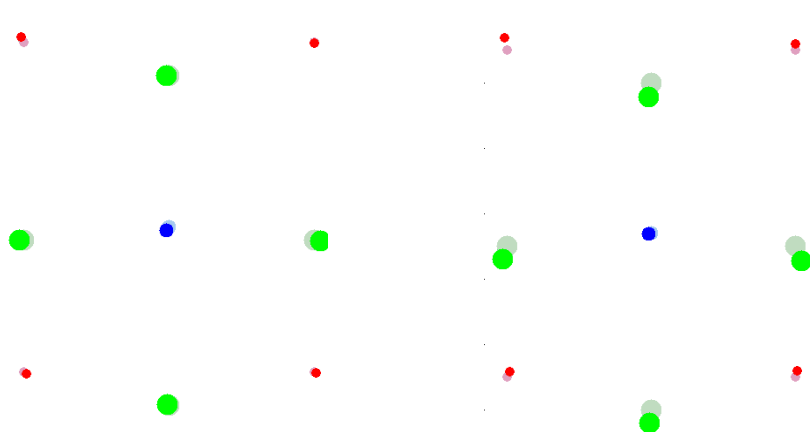

**Pump-Probe**

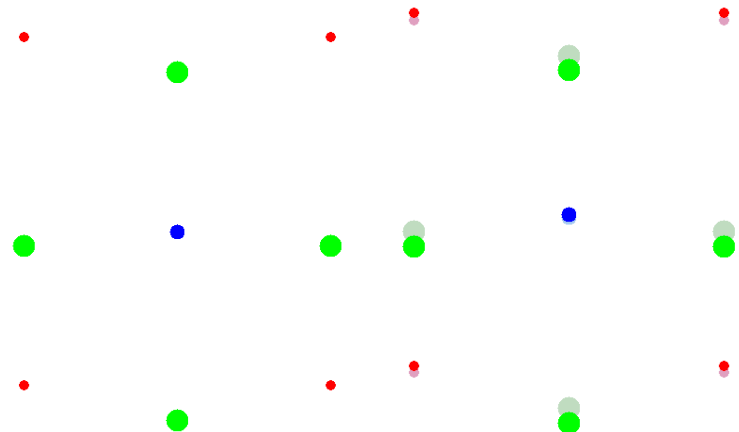

# Summary

- Intensity  $\rightarrow$  phonon amplitude (1.4 %)
- Shift of peaks  $\rightarrow$  expansion of structure  
pump fluence and time
- Assymetry  $\rightarrow$  inhomogeneous expansion
- Very large structure change directly evidenced by rocking curve
- Ultrafast X-ray Switch ( $< 1$  ps)
- Excitation mechanism
- Vary the PUMP wavelength / fluence
- Electron-phonon, phonon-phonon
- Magnon-phonon interaction
- Non-thermal population of phonons!

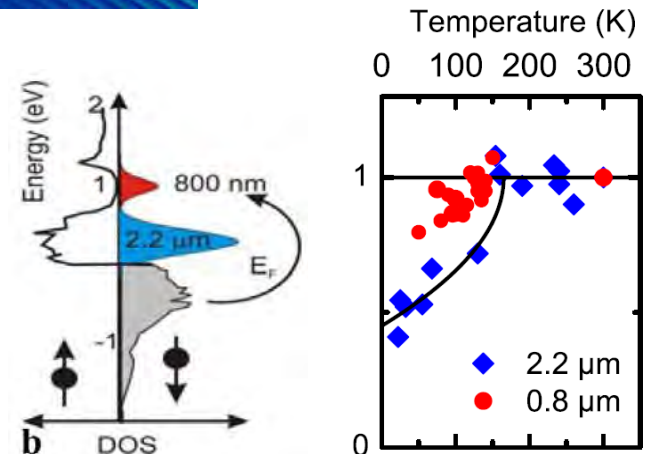
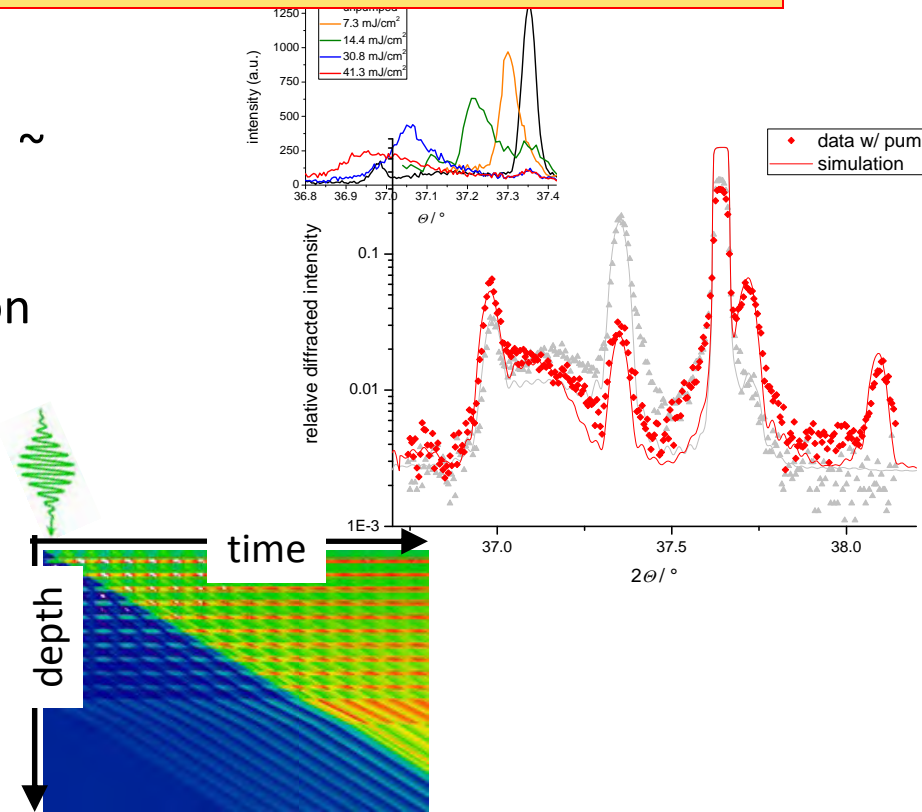

**Thank You !**

**Reviews:**

Clemens v. Korff Schmising et al, Z. Kristallogr. **223**, 283–291 (2008)

M. Bargheer, Atombewegung im Röntgenkinod  
Physik Journal **8**, 25701 (2007)

M. Bargheer et al., ChemPhysChem, **7**, 783-792 (2006)

Klaus Sokolowski-Tinten, J. Phys.: Condens. Matter **16**, R1517–R1536 (2004)

A.Rousse et al., Rev. Mod. Phys. **73**, 17 (2001)



**Join the team!**

**– open positions for PhD or PostDoc! –**