



# Optical afterburner for an X-ray FEL as a tool for pump-probe experiments

E.L. Saldin, E.A. Schneidmiller, M.V. Yurkov

FXE Workshop, Budapest, 9 Dec. 2009



- Introduction
- Developments at FLASH (soft X-ray FEL user facility)
- Proposals for the European XFEL
- Conclusions

Resolution is limited by:

- Pulse duration of pump and probe pulses
- Time jitter between the two pulses

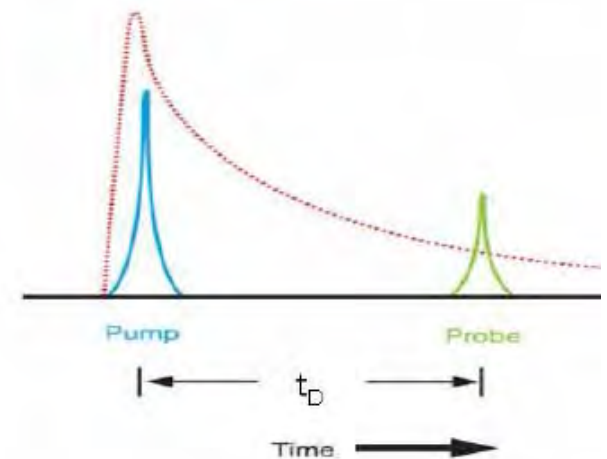
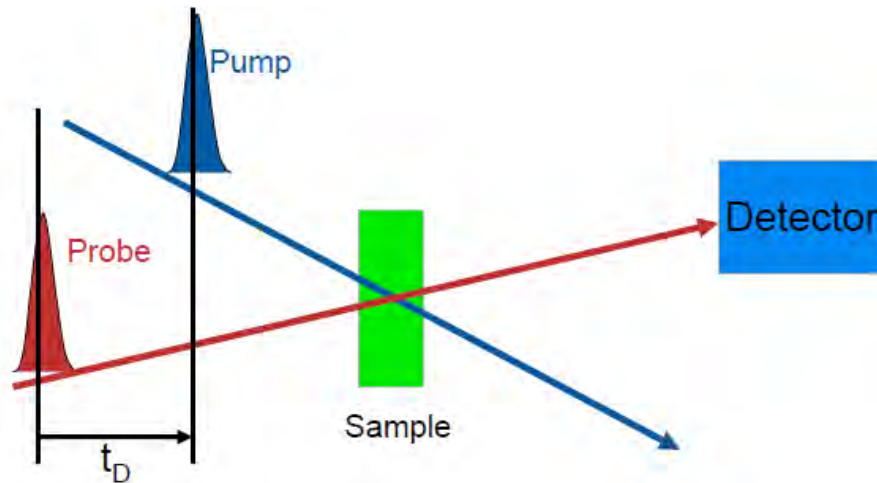

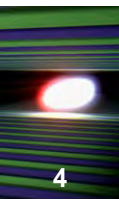

- At FLASH 10 fs long (FWHM) soft X-ray pulses are routinely delivered to users (single-digit fs pulses can be expected for harmonics)
- At LCLS low charge bunches (20 pC) are believed to produce single-digit fs pulses (hard and soft X-rays); first users already appreciate 20 pC option
- Powerful femtosecond optical lasers are available

There is the solid base for PP experiments at X-ray FELs with femtosecond resolution (few to 10 fs)

Main source of the jitter:

- Energy-dependent path length in magnetic bunch compressors. Jitter of RF amplitude and phase in accelerating modules translates into arrival time jitter.

Present status:

- Typical jitter of radiation pulses from FLASH is about **0.5 ps** (FWHM) when the beam is delivered to users
- Jitter of e-beam in LCLS linac was measured at about **100 fs** (FWHM)

**A large gap (1-2 orders of magnitude) between pulse durations and time jitters**

- Straightforward: improve RF stability
- More sophisticated:
  - global synchronization
  - electro-optical sampling (EOS)
  - beam arrival monitor (BAM)
  - beam-based feedback
  - dedicated user setup: use known process
- ...
- **Natural: produce two pulses of different colors (for instance, x-ray and optical pulses) by the same electron bunch.**

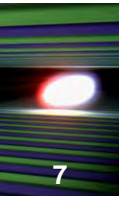

- Create e-beam density modulation (if it does not exist) in the desired wavelength range
- Use some radiator
- Transport optical beam to experiment and
  - use directly (if intense enough)
  - amplify and use
  - cross-correlate with a powerful PP laser and sort out the data



ELSEVIER

Nuclear Instruments and Methods in Physics Research A 475 (2001) 363–367

**NUCLEAR  
INSTRUMENTS  
& METHODS  
IN PHYSICS  
RESEARCH**  
Section A

[www.elsevier.com/locate/nima](http://www.elsevier.com/locate/nima)

## Development of a pump-probe facility combining a far-infrared source with laser-like characteristics and a VUV free electron laser

B. Faatz<sup>a,\*</sup>, A.A. Fateev<sup>b</sup>, J. Feldhaus<sup>a</sup>, J. Krzywinski<sup>c</sup>, J. Pflueger<sup>a</sup>,  
J. Rossbach<sup>a</sup>, E.L. Saldin<sup>a</sup>, E.A. Schneidmiller<sup>a</sup>, M.V. Yurkov<sup>b</sup>

<sup>a</sup> DESY, Deutsches Elektronen-Synchrotron, Notkestrasse 85, D-22603 Hamburg, Germany

<sup>b</sup> Joint Institute for Nuclear Research, Dubna, 141980 Moscow Region, Russia

<sup>c</sup> Institute of Physics of the Polish Academy of Sciences, 02688 Warszawa, Poland

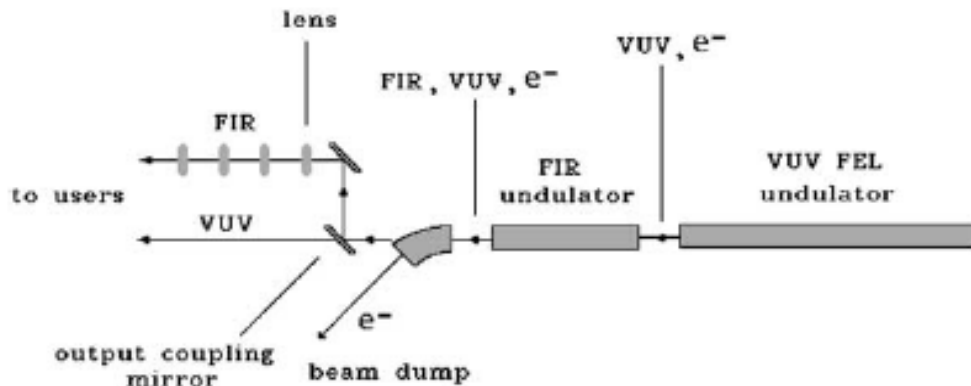

$$P(\lambda) = p_1(\lambda)[N_e + N_e(N_e - 1)|F(\lambda)|^2]$$

FIR undulator and THz beamline installed and commissioned in 2007-2008

(O.Grimm, M.Gensch et al.)

## Single-shot terahertz-field-driven X-ray streak camera

Ulrike Frühling<sup>1</sup>, Marek Wieland<sup>2</sup>, Michael Gensch<sup>1,3</sup>, Thomas Gebert<sup>2</sup>, Bernd Schütte<sup>2</sup>, Maria Krikunova<sup>2</sup>, Roland Kalms<sup>2</sup>, Filip Budzyn<sup>2</sup>, Oliver Grimm<sup>2,4</sup>, Jörg Rossbach<sup>2</sup>, Elke Plönjes<sup>1</sup> and Markus Drescher<sup>2\*</sup>

Courtesy Ulrike Frühling

FLASH: 13.5 nm  
FIR: 85  $\mu\text{m}$   
Gas: Krypton (4p)

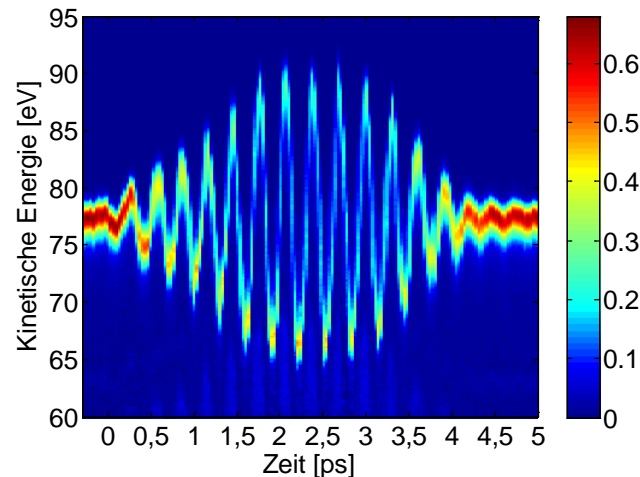

Two beams (FIR and soft X-ray) were transported about 100 m via separate beam lines and combined in time and space. **Measured time jitter was 5 fs rms** (about 10 fs FWHM).

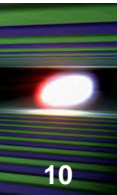

DESY 03-091  
July 2003

ISSN 0418-9833

## Two-color FEL amplifier for femtosecond-resolution pump-probe experiments with GW-scale X-ray and optical pulses

Published in  
Nucl.Instr. & Meth. A528(2004)453

J. Feldhaus<sup>a</sup>, M. Körfer<sup>a</sup>, T. Möller<sup>a</sup>, J. Pfüger<sup>a</sup>, E.L. Saldin<sup>a</sup>,  
E.A. Schneidmiller<sup>a</sup>, S. Schreiber<sup>a</sup>, and M.V. Yurkov<sup>b</sup>

<sup>a</sup>Deutsches Elektronen-Synchrotron (DESY), Notkestrasse 85, Hamburg, Germany

<sup>b</sup>Joint Institute for Nuclear Research, Dubna, 141980 Moscow Region, Russia

Proposal not accepted but ...

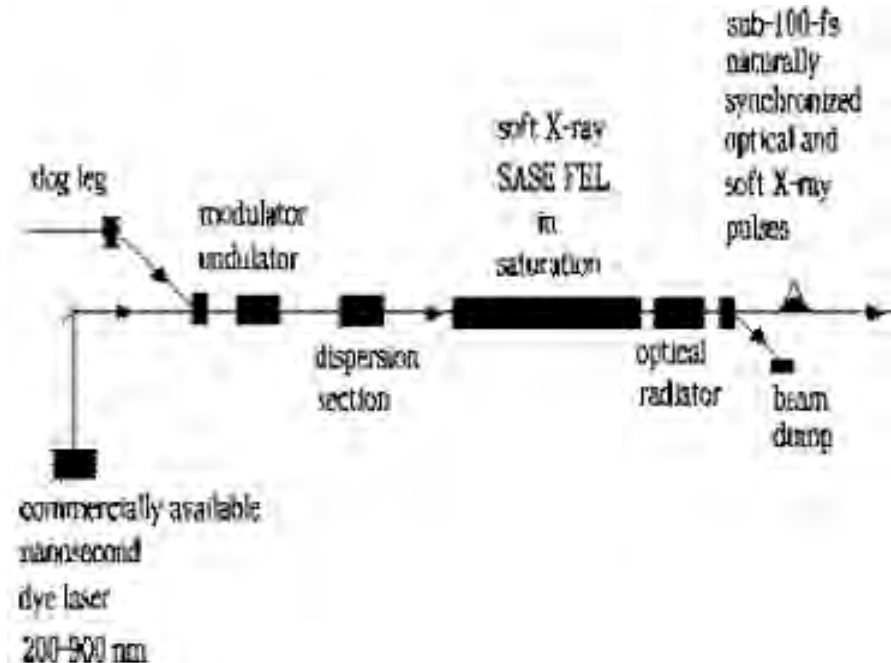

- ORFIR collaboration (M. Gensch et al.) combined two independent projects: **Optical Replica Synthesizer (ORS)** and **Far-Infrared Undulator**
- **Optical Replica Synthesizer** (Saldin et al.) is a device for diagnostics of ultra-short electron bunches. It was successfully commissioned this year (V. Ziemann et al.). It consists of a laser, two undulators, and a dispersion section (plus diagnostics). During the experiment the second undulator was off.
- **Far-Infrared Undulator** was tuned to laser wavelength, 770 nm
- **Strong coherent radiation from FIR undulator was detected: 1  $\mu$ J within a narrow band**
- **SASE FEL operation was not disturbed**

FLASH e-logbook, 20.03.09:

Summary from FEL users: we saw 1 micro Joule of 770 nm radiation in the THz beamline!

N.Stojanovic, F.Tavella, G.Geloni, M.Gensch, to be published

- Coherent THz radiation is produced in FIR undulator by a short electron bunch
- Alternatively, coherent edge radiation (THz) is produced by a short electron bunch behind SASE undulator (FIR undulator off)
- Radiation is transported down the THz beamline and cross-correlated with high-power PP laser
- Timing accuracy better than 5 fs rms is achieved (about 10 fs FWHM)

Concluding studies at FLASH: all basic ideas of the method (one bunch – two colors for PP) were successfully tested.

PP experiments with 10 fs resolution (or better?) are possible at FLASH.

It is easier now to make decisions for big machines like the European XFEL.

G.Geloni et al., Opt. Commun. 281(2008)3762

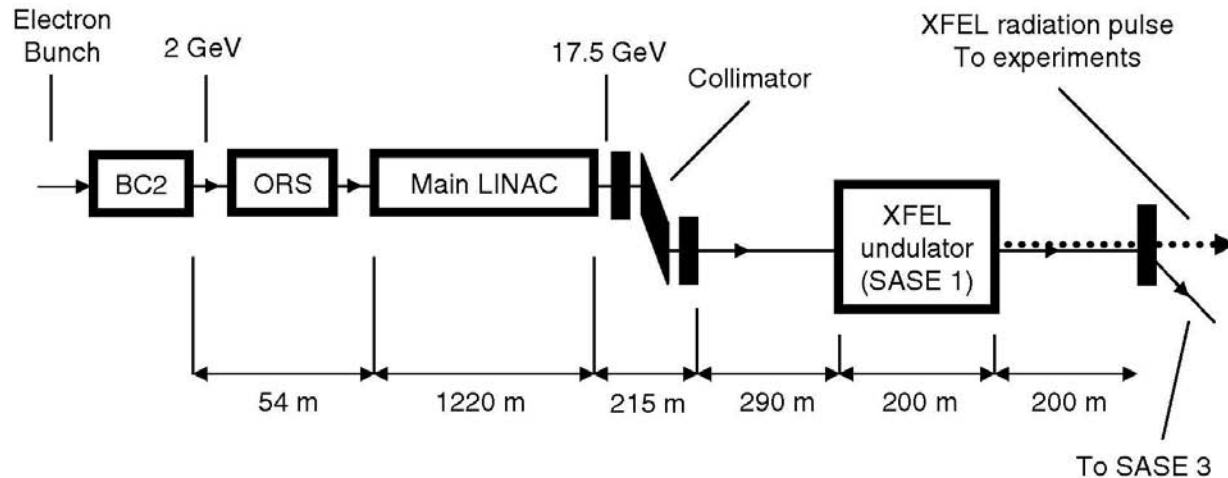

- Use **Optical Replica Synthesizer (ORS)\*** to modulate the beam (400 nm)
- Coherent edge radiation (about  $10^{12}$  photons) is produced behind XFEL undulator
- Transport the optical beam to experimental hall and do cross-correlation with a high-power laser
- **All these ideas were tested at FLASH!**

\*Decision on ORS for European XFEL still to be made

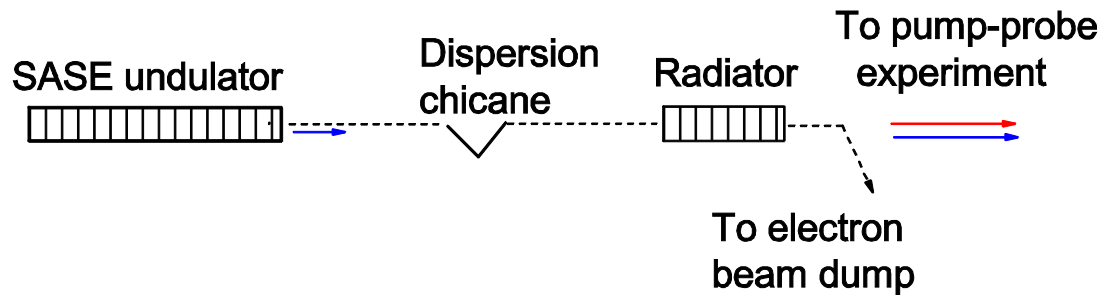

- Very simple scheme, does not require external lasers etc.
- Uses intrinsic features of SASE process

SSY, submitted to Phys. Rev. ST-AB

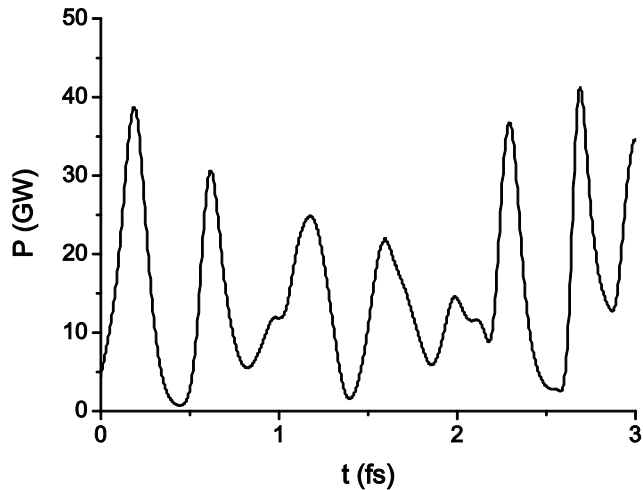

SASE1 power at saturation:  
typical feature size is 0.3 fs (100 nm)

- Optical frequencies appear in electron beam phase space (time-energy) due to nonlinearities of the SASE FEL process
- These frequencies appear in energy modulations but not in density modulations
- Install a compact dispersion section (4-bend chicane) that converts energy modulations into density modulations
- Longitudinal dispersion is characterized by  $R_{56}$  element:

$$\Delta s = R_{56} \Delta E/E_0$$

SSY, submitted to Phys. Rev. ST-AB

TDR case:

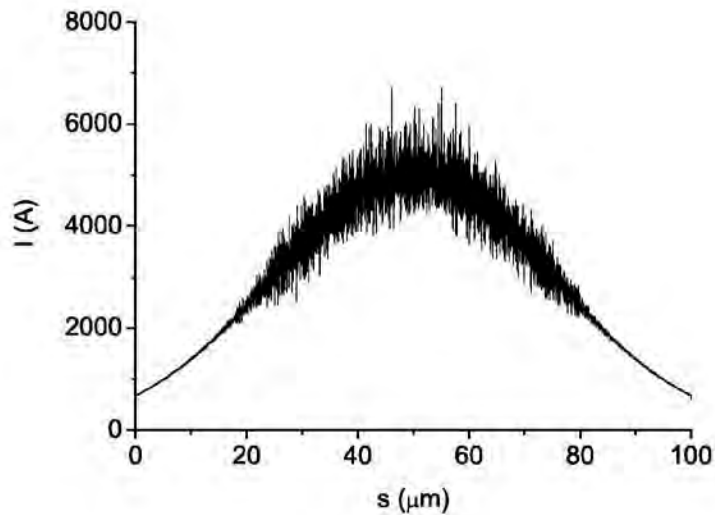
1 nC,  $\varepsilon_n = 1.4 \text{ mm} \cdot \text{mrad}$  $R_{56} = 50 \text{ } \mu\text{m}$ 

Low emittance case:

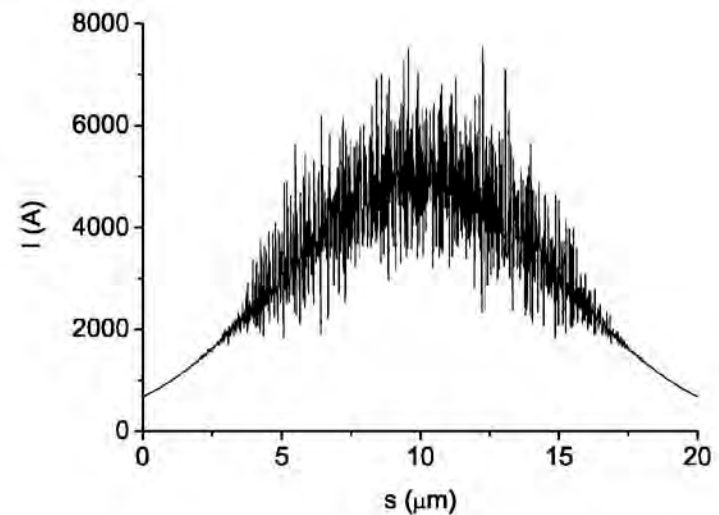
200 pC,  $\varepsilon_n = 0.4 \text{ mm} \cdot \text{mrad}$  $R_{56} = 10 \text{ } \mu\text{m}$ 

SSY, submitted to Phys. Rev. ST-AB

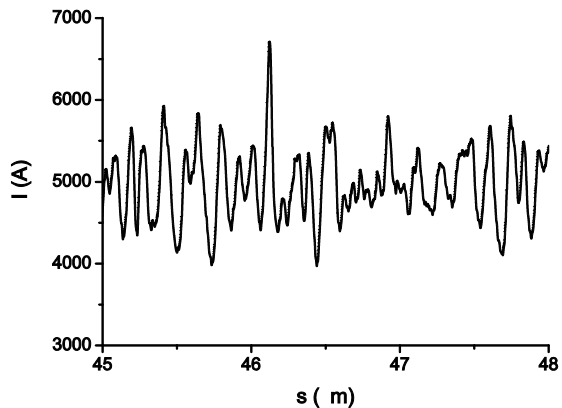
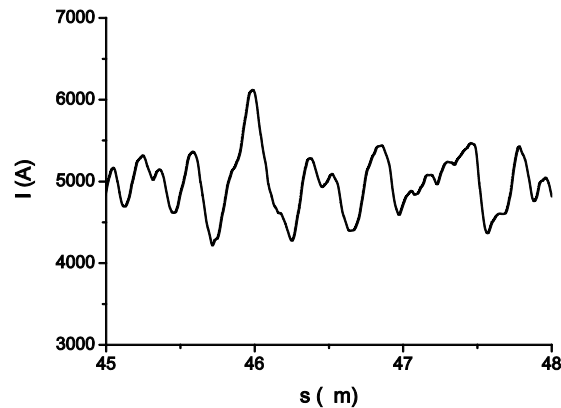
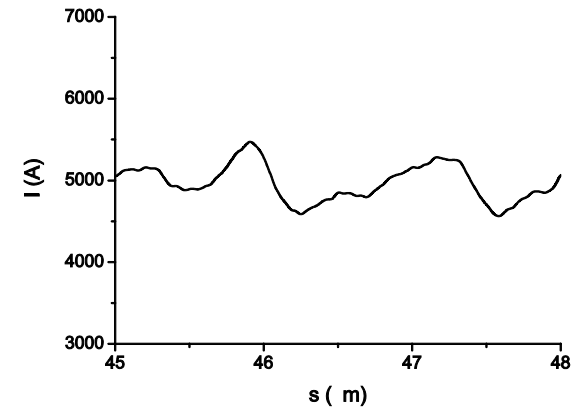
$R_{56} = 50 \mu\text{m}$  $R_{56} = 200 \mu\text{m}$  $R_{56} = 500 \mu\text{m}$ 

One can control modulation scale by changing  $R_{56}$

SSY, submitted to Phys. Rev. ST-AB

Solid:  $R_{56} = 50 \mu\text{m}$ , dot:  $R_{56} = 200 \mu\text{m}$ , dash:  $R_{56} = 500 \mu\text{m}$

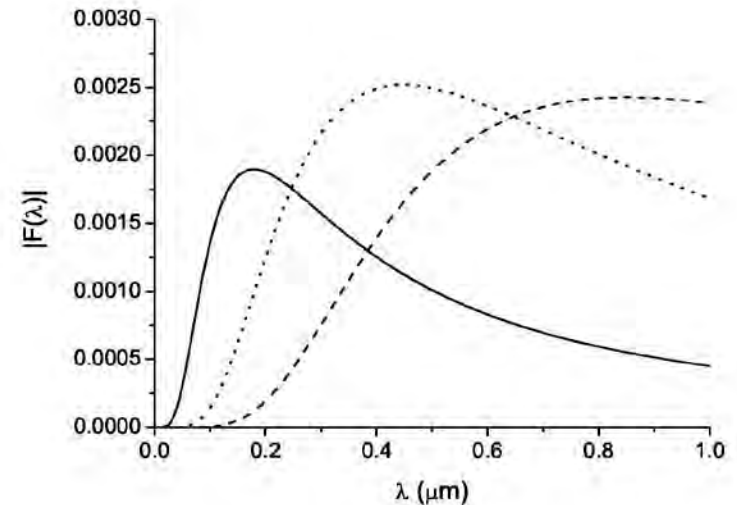
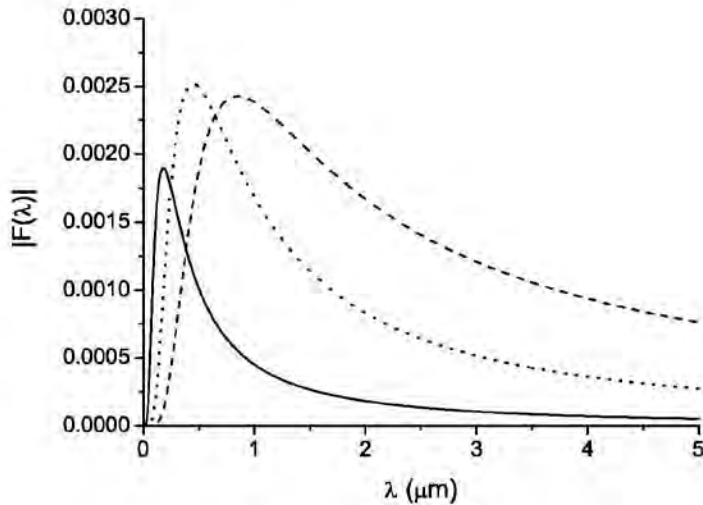

$$F(\lambda) = \int_{-\infty}^{\infty} ds f(s) e^{i2\pi s/\lambda}$$

$$P(\lambda) = p_1(\lambda) [N_e + N_e(N_e - 1)|F(\lambda)|^2]$$

SSY, submitted to Phys. Rev. ST-AB

Solid:  $R_{56} = 50 \mu\text{m}$ , dot:  $R_{56} = 200 \mu\text{m}$ , dash:  $R_{56} = 500 \mu\text{m}$

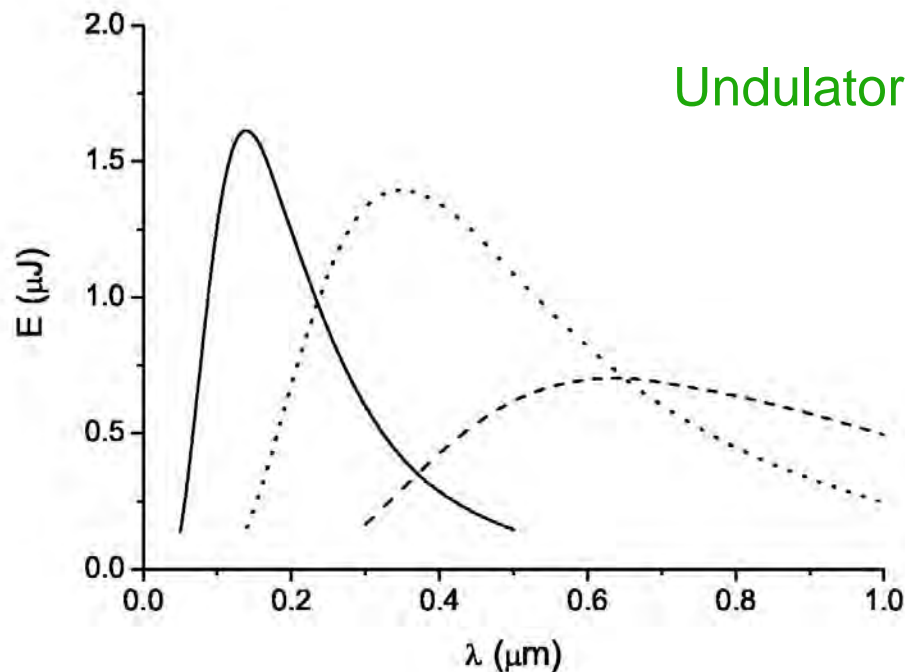

Undulator is similar to that installed in FLASH:

10 periods,  
period length 70 cm,  
maximum field 1.2 T

within coherent angle, 10% BW

pulse energy fluctuations below 10%

SSY, submitted to Phys. Rev. ST-AB

## Advantages:

- Cheap and robust method
- Pulse width the same as that of SASE pulse, perfect timing down to sub-fs for hard x-rays
- Wider spectral range available
- On-line monitoring of SASE pulse width possible

## Disadvantages:

- Less power (in case of undulator)
- Intrinsic shot-to-shot fluctuations of pulse energy

- For chaotic modulations: comparable power (pulse energy), but spectral brightness higher by number of periods
- For periodic modulations the power (and pulse energy) increases linearly with number of periods. For reference: 10% density modulation at 400 nm would result in 25  $\mu\text{J}$  for considered bunch and undulator
- Und. radiation is easier to handle (edge radiation is radially polarized, has rings in angular distribution)
- Divergence is larger for undulator radiation: 200 microradian (at 400 nm) versus 50 microradian

- “Visualization” of X-ray pulse, i.e. translating its width and shape into optical range (making “optical replica”)
- On-line measurement with FROG or its relatives
- Radiator:  $\Delta\omega \gg 1/\Delta T_{sase}$
- Measure ensemble-average envelope (adjacent averaging possible)
- Works well for linear regime, some broadening at saturation

SSY, submitted to Phys. Rev. ST-AB

Simulation of single shot reconstruction: SASE1 at saturation.

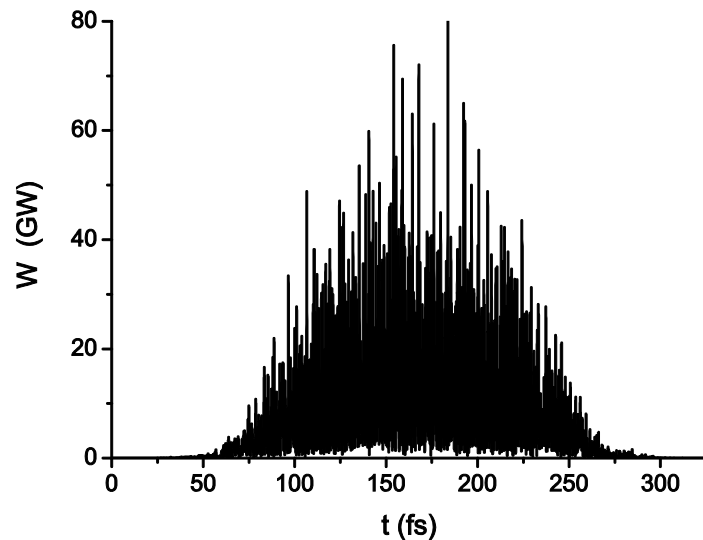

single shot

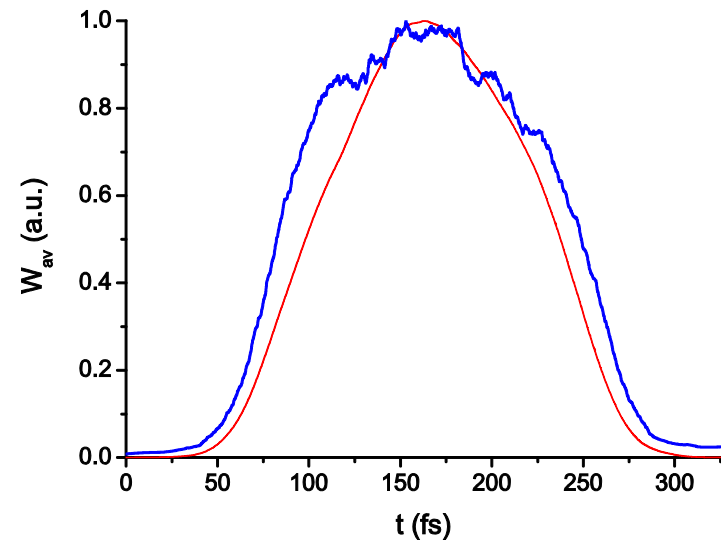

red: ensemble average FEL power

blue: reconstruction (adjacent averaging used)

SSY, submitted to Phys. Rev. ST-AB

- Two-color schemes resolve jitter issue: proven at FLASH
- For European XFEL two scenarios are proposed, can be realized simultaneously
- Optical Replica Synthesizer would be very useful
- Minimal extension of XFEL: compact dispersion section behind SASE undulator (use edge radiation)
- Next step: install undulator resonant to optical frequencies
- Robust on-line monitoring of SASE pulse duration is possible
- Similar afterburners can be installed behind SASE2 and SASE3